



Totally Focused. Totally Independent.

Technical Guide

---

EC038 4 A



The world's largest  
independent producer of  
alternators 1 – 5,000kVA



## Standards

Alternators are designed and produced within an ISO 9001 environment. The entire series is manufactured according to, and complies with, the most common specifications such as CEI 2-3, IEC 34-1, EN 60034-1, VDE 0530, BS 4999-5000, NF 51.111, CAN/CSA-C22.2 No14-95-No100-95, NEMA MG 1-2011, ISO 8528-3. Other standards such as UL1446, UL 1004/4 and /B are available on request.

## Windings and Performances

All windings are 2/3rds pitch to eliminate triplen harmonics within the voltage waveform and to avoid excessive neutral currents in certain parallel operating conditions. A fully interconnected aluminium or copper damper cage is supplied on the rotor of all models (excluding the ECP3 series).

- ▶ 12 wire reconnectable:
  - 50Hz – 380V to 440V and 220/110V to 240/120V (de-rates may apply at certain voltages)
  - 60Hz – 380V to 480V and 220/110V to 240/120V (de-rates may apply at certain voltages)
- ▶ 6 wire reconnectable:
  - 50Hz – 380V to 440V and 220V to 240V (de-rates may apply at certain voltages)
  - 60Hz – 380V to 480V and 220V to 240V (de-rates may apply at certain voltages)

Winding Configurations	Standard		Special (dedicated)			
	12 wire Reconnectable	6 wire Reconnectable	380V and 600V 60Hz	690V 50/60Hz	220-240V 1ph 50Hz	220-240V 1ph 60Hz
ECP3 to ECO38	Std	Option	Option	Option	Option	Option
ECO40 to ECO46	Std	Option	Option	Option	Option (to ECO40)	Option (to ECO40)
Insulation materials	Class H	Class H	Class H	Class H	Class H	Class H
High efficiency	Std	Std	Std	Std	Std	Std
High motor starting	>300%	>300%	>300%	>300%	>300%	>300%
THD (Total Harmonic Distortion)	Typically <3.5% full load L-L	Typically <3.0% full load L-L	Typically <3.5% full load L-L	Typically <3.5% full load L-L	Typically <4.5% full load L-N	Typically <4.5% full load L-N
Interference suppression	VDE 0875 G/N/K, EN61000-6-3, EN61000-6-2, others available on request					

## Winding Protection

There are various degrees of protection for the windings following the standard impregnation process, as can be seen here. The TOTAL+ butadienic black flexible coating is recommended for arduous applications.

Winding Protection:	STANDARD	STANDARD+	GREY	GREY+	TOTAL+
ECP3	Std	Option	Option	Option	Option
ECP28 and ECP32	-	Std	Option	Option	Option
NPE32, ECP34 to ECO46	-	-	Std	Option	Option



Grey treatment (marinization) on the left, TOTAL+ treatment shown on the right. The EG43 grey varnish, is an high temperature insulating enamel that forms a tough and flexible film, with excellent moisture and chemical protection. It is water and oil proof, and also protects windings from abrasion. It is applied spraying an over coating layer over the impregnated winding, or dipping the stator in a varnish barrel for superior treatments

The TOTAL+ is a protection system that makes Mecc Alte special. It is the ultimate winding treatment that offers truly superior performances when the environment is really harsh, or the application very demanding. The TOTAL+ is also extremely resistant to the particle abrasion as it adsorbs the impacts.

## Protection for Environment

In addition to protection on the windings themselves, the alternators can have increased ingress protection. Standard levels are IP23 with further upgrades available to include inlet filters, IP43 and IP45: 7% de-rates apply on inlet filters and IP43 protection. 20-30% de-rates apply for IP45 depending on alternator model.

Additional air exit louvres (called IP23+) are optionably retrofittable in the overall ECP32 to ECO 46 range, in order to comply to the most strict marine regulations.

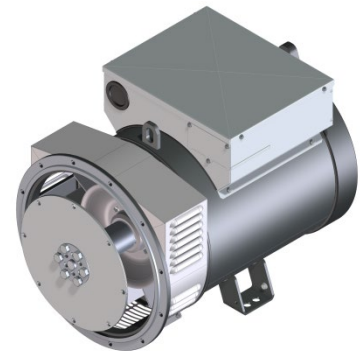

## Construction

The robust mechanical structure withstands up to 5G in any direction and 9G vertically and its design permits easy access to the connections and components during routine maintenance check-ups. The mechanical design has used the most advanced FEM techniques. The materials used are: FEP12 steel for the frame, C45 steel for the shaft and cast iron or aluminum pressure die cast for the end-brackets: fans are aluminum die casted either nylon fiber glass loaded, UL compliant materials. Rotors are dynamically balanced according grade 2.5 of ISO 1940-1.

## Terminals and Terminal Box

Easy access to regulators is assured through a pull out drawer or a drop down panel to allow safer adjustment. Large terminal boxes allow easy access of power cables, in the ECO43 and ECO46 higher power ranges the terminal allow the convenient choice of power cable or busbar connection with versatility of entry and connection. Current transformers are available as an option on series ECO 40, 43 and 46 with single or dual output.

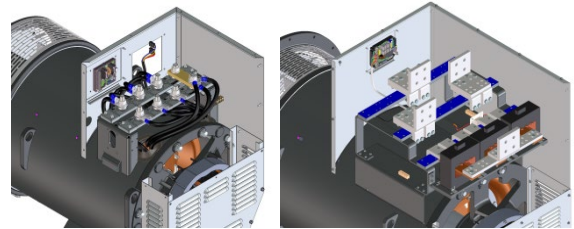

## Excitation and Regulation Systems

All ECP/ECO series have MAUX auxiliary winding to power the digital regulator. Both DSR and the DER1 are available to connect to PC through the DxR2 USB interface and DxR TERMINAL software to interrogate/download alarms & settings for analysis or for cloning other regulators. DER2 has got an integrated USB connection and can be connected to the PC without any optional connection boards. More settings such as LAMS, digital RAM based synchronous external control and soft start are obtainable through the DxR connection. Simple analogue potentiometers are available for the more usual adjustments.

Excitation Systems	DSR	DER1	DER2
ECP3 to ECO38	Std	Option	Option
ECO40 to ECO46	-	Std	Option
Parallel Operation	√	√	√
Mains Parallel	√	√	√
3 Phase Sensing (rms)	-	√	√
Accuracy	+/-1%	+/-0.5%	+/-0.5%
Remote Voltage Control	√	√	√
Alarm Log	√	√	√
Analogue and Digital Configurable	√	√	√
LAMS (Load Acceptance V/f)	√	√	√
APO (Active Protection Output)	√	√	√
Soft Start	√	√	√
High dynamic response	-	-	√
USB connection without external boards	-	-	√

For a given motor start duty a smaller machine may be selected – also enhanced by low sub-transient reactance values for non-linear loads. The whole range from 6.5 to 3400kVA is capable of >300% sustained short circuit current for up to 20 seconds.

## Optional PMG3

PMG3 can be retro fit or factory fit on ECO 40, 43 and 46 series. This smart MeccAlte design allows an easy fix kit, through a tapered cone coupling and a simple replacement of the rear air louvre. PMG3 is also available on ECO 38, when ordered from the factory.

The complete AVR range is fully compatible with both MAUX and PMG3 systems, this minimises spare part management and flexibility of stock as one AVR suits all applications. The PMG3 is delivering the same amount of kVA available with the MAUX.

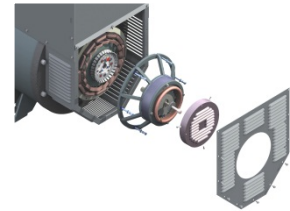

## Accessories

Additional optionals can be fit on our alternator series, such as PTC thermistors or PT100 both on windings and bearings, space heaters, high and low profile of terminal boxes (on most series), air filter clogging sensors, rotating diode bridge failure sensor (RBD), power factor controller for parallel operation (PFR/2), parallel devices (standard from ECO 40), air filters, IP43 and IP45 protections, marine IP23 + protection for SOLAS requirements and many others.

## Deration coefficients

Altitude (meters)	Ambient temperature (Celsius)					
	25	40	45	50	55	60
$\leq 1000$	1.07	1	0.96	0.93	0.91	0.89
$> 1000 \leq 1500$	1.01	0.96	0.92	0.89	0.87	0.84
$> 1500 \leq 2000$	0.96	0.91	0.87	0.84	0.83	0.79
$> 2000 \leq 3000$	0.9	0.85	0.81	0.78	0.76	0.73

## Notes on short circuit curves

The indicated coefficients have to be used to correct the three phase short circuit curves values as a function of the rated voltage.

The indicated coefficient have to be used to correct the three phase short circuit curves values as a function of the type of short circuit voltage.

50 Hz		60 Hz	
Voltage	Factor	Voltage	Factor
380	0.93X	415	0.85X
400	1X	440	0.90X
415	1.04X	460	0.95X
440	1.10X	480	1X

	3 phase	2 phase L-L	1 phase L-N
<i>Istantaneous</i>	1X	0.87X	1.30X
<i>Minimum</i>	1X	1.80X	3.20X
<i>Sustained</i>	1X	1.50X	2.50X
<i>Max Duration</i>	20 sec.	10 sec.	4 sec.

All the curves are shown for series or parallel star connection at 400V 50 Hz or 480V 60 Hz. If the unit is reconnected from series to parallel star, the additional coefficient is 2X. From series star to series delta, it is 1.72X. From series star to parallel delta, it is 3.44X.

### General characteristics

Pole number	4	Insulation class	H
Phase number	3	Protection class	IP23
Number of wires	12	NDE Bearing type	6314.2RS
Execution	Brushless	DE Bearing type	6318.2RS
Regulator type	DSR	Maximum Overspeed	2250
Winding pitch	2/3	Altitude	0-1000
Code voltage reference	T0405S3	Balancing	ISO1940-1

### Ratings 50Hz

kVA / kW @ Temp. Rise / Ambient °C - 0.8 PF		STANDBY-163/27				STANDBY-150/40				H-125/40				F-105/40				B-80/40			
Series	Star Y	380V	400V	415V	440V	380V	400V	415V	440V	380V	400V	415V	440V	380V	400V	415V	440V	380V	400V	415V	440V
	Parallel Star YY	190V	200V	208V	220V	190V	200V	208V	220V	190V	200V	208V	220V	190V	200V	208V	220V	190V	200V	208V	220V
	Series Delta Δ	220V	230V	240V	254V	220V	230V	240V	254V	220V	230V	240V	254V	220V	230V	240V	254V	220V	230V	240V	254V
	Parallel Delta ΔΔ	110V	115V	120V	127V	110V	115V	120V	127V	110V	115V	120V	127V	110V	115V	120V	127V	110V	115V	120V	127V
<b>ECO38 154 A</b>	<b>kVA</b>	196	<b>196</b>	196	180	188	<b>188</b>	188	173	180	<b>180</b>	180	165	170	<b>170</b>	170	155	144	<b>144</b>	144	132
	<b>kW</b>	157	<b>157</b>	157	144	150	<b>150</b>	150	138	144	<b>144</b>	144	132	136	<b>136</b>	136	124	115	<b>115</b>	115	106
<b>ECO38 254 A</b>	<b>kVA</b>	220	<b>220</b>	220	209	211	<b>211</b>	211	200	200	<b>200</b>	200	190	185	<b>185</b>	185	175	160	<b>160</b>	160	152
	<b>kW</b>	176	<b>176</b>	176	167	169	<b>169</b>	169	160	160	<b>160</b>	160	152	148	<b>148</b>	148	140	128	<b>128</b>	128	122
<b>ECO38 354 A</b>	<b>kVA</b>	250	<b>250</b>	250	234	237	<b>237</b>	237	221	225	<b>225</b>	225	210	207	<b>207</b>	207	190	180	<b>180</b>	180	168
	<b>kW</b>	200	<b>200</b>	200	187	190	<b>190</b>	190	177	180	<b>180</b>	180	168	166	<b>166</b>	166	152	144	<b>144</b>	144	134
<b>ECO38 1L4 A</b>	<b>kVA</b>	275	<b>275</b>	275	253	264	<b>264</b>	264	243	250	<b>250</b>	250	230	230	<b>230</b>	230	215	200	<b>200</b>	200	184
	<b>kW</b>	220	<b>220</b>	220	202	211	<b>211</b>	211	194	200	<b>200</b>	200	184	184	<b>184</b>	184	172	160	<b>160</b>	160	147
<b>ECO38 2L4 A</b>	<b>kVA</b>	330	<b>330</b>	330	319	315	<b>315</b>	315	305	300	<b>300</b>	300	290	275	<b>275</b>	275	265	240	<b>240</b>	240	232
	<b>kW</b>	264	<b>264</b>	264	255	252	<b>252</b>	252	244	240	<b>240</b>	240	232	220	<b>220</b>	220	212	192	<b>192</b>	192	186
<b>ECO38 3L4 A</b>	<b>kVA</b>	370	<b>370</b>	370	360	360	<b>360</b>	360	350	350	<b>350</b>	350	340	320	<b>320</b>	320	310	280	<b>280</b>	280	272
	<b>kW</b>	296	<b>296</b>	296	288	288	<b>288</b>	288	280	280	<b>280</b>	280	272	256	<b>256</b>	256	248	224	<b>224</b>	224	218

### Ratings 60Hz

kVA / kW @ Temp. Rise / Ambient °C - 0.8 PF		STANDBY-163/27				STANDBY-150/40				H-125/40				F-105/40				B-80/40			
Series	Star Y	415V	440V	460V	480V	415V	440V	460V	480V	415V	440V	460V	480V	415V	440V	460V	480V	415V	440V	460V	480V
	Parallel Star YY	208V	220V	230V	240V	208V	220V	230V	240V	208V	220V	230V	240V	208V	220V	230V	240V	208V	220V	230V	240V
	Series Delta Δ	240V	254V	265V	277V	240V	254V	265V	277V	240V	254V	265V	277V	240V	254V	265V	277V	240V	254V	265V	277V
	Parallel Delta ΔΔ	120V	127V	133V	138V	120V	127V	133V	138V	120V	127V	133V	138V	120V	127V	133V	138V	120V	127V	133V	138V
<b>ECO38 154 A</b>	<b>kVA</b>	225	236	236	<b>236</b>	220	230	230	<b>230</b>	210	220	220	<b>220</b>	195	205	205	<b>205</b>	168	176	176	<b>176</b>
	<b>kW</b>	180	189	189	<b>189</b>	176	184	184	<b>184</b>	168	176	176	<b>176</b>	156	164	164	<b>164</b>	134	141	141	<b>141</b>
<b>ECO38 254 A</b>	<b>kVA</b>	253	264	264	<b>264</b>	242	253	253	<b>253</b>	230	240	240	<b>240</b>	210	220	220	<b>220</b>	184	192	192	<b>192</b>
	<b>kW</b>	202	211	211	<b>211</b>	194	202	202	<b>202</b>	184	192	192	<b>192</b>	168	176	176	<b>176</b>	147	154	154	<b>154</b>
<b>ECO38 354 A</b>	<b>kVA</b>	289	300	300	<b>300</b>	274	284	284	<b>284</b>	260	270	270	<b>270</b>	240	250	250	<b>250</b>	208	216	216	<b>216</b>
	<b>kW</b>	231	240	240	<b>240</b>	219	227	227	<b>227</b>	208	216	216	<b>216</b>	192	200	200	<b>200</b>	166	173	173	<b>173</b>
<b>ECO38 1L4 A</b>	<b>kVA</b>	319	330	330	<b>330</b>	305	316	316	<b>316</b>	290	300	300	<b>300</b>	270	280	280	<b>280</b>	232	240	240	<b>240</b>
	<b>kW</b>	255	264	264	<b>264</b>	244	253	253	<b>253</b>	232	240	240	<b>240</b>	216	224	224	<b>224</b>	186	192	192	<b>192</b>
<b>ECO38 2L4 A</b>	<b>kVA</b>	358	374	396	<b>396</b>	341	357	378	<b>378</b>	325	340	360	<b>360</b>	300	310	330	<b>330</b>	260	272	288	<b>288</b>
	<b>kW</b>	286	299	317	<b>317</b>	273	286	302	<b>302</b>	260	272	288	<b>288</b>	240	248	264	<b>264</b>	208	218	230	<b>230</b>
<b>ECO38 3L4 A</b>	<b>kVA</b>	402	444	444	<b>444</b>	391	438	438	<b>438</b>	380	420	420	<b>420</b>	350	385	385	<b>385</b>	304	336	336	<b>336</b>
	<b>kW</b>	322	355	355	<b>355</b>	313	350	350	<b>350</b>	304	336	336	<b>336</b>	280	308	308	<b>308</b>	243	269	269	<b>269</b>

## Reactance &amp; Time constants- Class H / 400V

Unsaturated (ref. EN60034-4)			ECO38 154 A	ECO38 254 A	ECO38 354 A	ECO38 1L4 A	ECO38 2L4 A	ECO38 3L4 A
<b>X<sub>d</sub></b>	Direct-axis synchronous reactance	%	203,9	207	198,7	214,2	215,3	222,5
<b>X'<sub>d</sub></b>	Direct-axis transient reactance	%	10	11,4	12,7	14,5	15,8	17,8
<b>X''<sub>d</sub></b>	Direct-axis subtransient reactance	%	5,69	6,11	6,72	7,45	8,38	9,73
<b>X<sub>q</sub></b>	Quadrature-axis synchronous reactance	%	100,3	113,8	109,7	121,1	124,2	130,4
<b>X'<sub>q</sub></b>	Quadrature-axis transient reactance	%	100,3	113,8	109,7	121,1	124,2	130,4
<b>X''<sub>q</sub></b>	Quadrature-axis subtransient reactance	%	20,4	22,2	23	22,8	21,5	20,8
<b>X<sub>2</sub></b>	Negative-sequence reactance	%	13,2	14,8	15,9	16,6	16,7	16,2
<b>X<sub>0</sub></b>	Zero sequence reactance	%	2,79	2,59	2,69	2,48	2,38	2,28
Saturated								
<b>X<sub>d</sub></b>	Direct-axis synchronous reactance	%	169,2	171,8	164,9	177,8	178,7	184,7
<b>X'<sub>d</sub></b>	Direct-axis transient reactance	%	8,33	9,45	10,5	12	13,1	14,8
<b>X''<sub>d</sub></b>	Direct-axis subtransient reactance	%	4,72	5,07	5,58	6,19	6,96	8,08
<b>X<sub>q</sub></b>	Quadrature-axis synchronous reactance	%	83,2	94,5	91	100,5	103,1	108,2
<b>X'<sub>q</sub></b>	Quadrature-axis transient reactance	%	83,2	94,5	91	100,5	103,1	108,2
<b>X''<sub>q</sub></b>	Quadrature-axis subtransient reactance	%	16,9	18,5	19,1	18,9	17,9	17,3
<b>X<sub>2</sub></b>	Negative-sequence reactance	%	11	12,3	13,2	13,7	13,8	13,5
<b>X<sub>0</sub></b>	Zero sequence reactance	%	2,79	2,59	2,69	2,48	2,38	2,28
<b>K<sub>cc</sub></b>	Short circuit ratio		0,44	0,46	0,45	0,44	0,43	0,42
<b>T'<sub>d</sub></b>	Transient time constant	sec	0,073	0,078	0,083	0,085	0,091	0,099
<b>T''<sub>d</sub></b>	Subtransient time constant	sec	0,011	0,012	0,013	0,013	0,012	0,013
<b>T'<sub>do</sub></b>	Open circuit time constant	sec	0,7	0,9	1,1	1,3	1,4	1,5
<b>T<sub>a</sub></b>	Armature time constant	sec	0,015	0,016	0,018	0,017	0,016	0,013

## Additional information - Class H / 400V

<b>I<sub>0</sub></b>	Excitation current at no load	A	0,7	0,7	0,67	0,71	0,78	0,72
<b>I<sub>c</sub></b>	Excitation current at full load	A	3,1	3,0	3,0	2,8	3,9	3,9
Overload								
Overload per 20 sec. PRP or 10 sec. COP						300		
Heat dissipation		W	11844	12600	13548	14133	16137	19465
Telephone Harmonic Factor - THF		%	<2	<2	<2	<2	<2	<2
Waveform Distors.(THD) full load LL/LN		%	3,1 / 3	3 / 2,9	2,8 / 2,9	2,9 / 3,1	3 / 2,9	3,1 / 2,9
Waveform Distors.(THD) no load LL/LN		%	2,8 / 2,7	2,7 / 2,6	2,6 / 2,8	2 / 2,1	2,6 / 2,8	2,7 / 2,7



## Reactance &amp; Time constants- Class H / 480V

Unsaturated (ref. EN60034-4)			ECO38 154 A	ECO38 254 A	ECO38 354 A	ECO38 1L4 A	ECO38 2L4 A	ECO38 3L4 A
<b>X<sub>d</sub></b>	Direct-axis synchronous reactance	%	207,7	207	198,7	214,2	215,3	222,5
<b>X'<sub>d</sub></b>	Direct-axis transient reactance	%	10,2	11,4	12,7	14,5	15,8	17,8
<b>X''<sub>d</sub></b>	Direct-axis subtransient reactance	%	5,8	6,11	6,72	7,45	8,38	9,73
<b>X<sub>q</sub></b>	Quadrature-axis synchronous reactance	%	102,1	113,8	109,7	121,1	124,2	130,4
<b>X'<sub>q</sub></b>	Quadrature-axis transient reactance	%	102,1	113,8	109,7	121,1	124,2	130,4
<b>X''<sub>q</sub></b>	Quadrature-axis subtransient reactance	%	20,8	22,2	23	22,8	21,5	20,8
<b>X<sub>2</sub></b>	Negative-sequence reactance	%	13,5	14,8	15,9	16,6	16,7	16,2
<b>X<sub>0</sub></b>	Zero sequence reactance	%	2,85	2,59	2,69	2,48	2,38	2,28
Saturated								
<b>X<sub>d</sub></b>	Direct-axis synchronous reactance	%	172,4	171,8	164,9	177,8	178,7	184,7
<b>X'<sub>d</sub></b>	Direct-axis transient reactance	%	8,49	9,45	10,5	12	13,1	14,8
<b>X''<sub>d</sub></b>	Direct-axis subtransient reactance	%	4,81	5,07	5,58	6,19	6,96	8,08
<b>X<sub>q</sub></b>	Quadrature-axis synchronous reactance	%	84,8	94,5	91	100,5	103,1	108,2
<b>X'<sub>q</sub></b>	Quadrature-axis transient reactance	%	84,8	94,5	91	100,5	103,1	108,2
<b>X''<sub>q</sub></b>	Quadrature-axis subtransient reactance	%	17,2	18,5	19,1	18,9	17,9	17,3
<b>X<sub>2</sub></b>	Negative-sequence reactance	%	11,2	12,3	13,2	13,7	13,8	13,5
<b>X<sub>0</sub></b>	Zero sequence reactance	%	2,85	2,59	2,69	2,48	2,38	2,28
<b>K<sub>cc</sub></b>	Short circuit ratio		0,44	0,46	0,45	0,44	0,43	0,42
<b>T'<sub>d</sub></b>	Transient time constant	sec	0,073	0,078	0,083	0,085	0,091	0,099
<b>T''<sub>d</sub></b>	Subtransient time constant	sec	0,011	0,012	0,013	0,013	0,012	0,013
<b>T'<sub>do</sub></b>	Open circuit time constant	sec	0,7	0,9	1,1	1,3	1,4	1,5
<b>T<sub>a</sub></b>	Armature time constant	sec	0,015	0,016	0,018	0,017	0,016	0,013

## Additional information - Class H / 480V

<b>I<sub>o</sub></b>	Excitation current at no load	A	0,65	0,65	0,65	0,7	0,7	0,7
<b>I<sub>c</sub></b>	Excitation current at full load	A	3,0	2,9	2,9	2,8	3,8	3,9
Overload								
Overload per 20 sec. PRP or 10 sec. COP						300		
Heat dissipation		W	12437	12691	13299	13968	16118	20310
Telephone Interference Factor - TIF			<40	<40	<40	<40	<40	<40
Waveform Distors.(THD) full load LL/LN		%	3,1 / 3	3 / 2,9	2,8 / 2,9	2,9 / 3,1	3 / 2,9	3,1 / 2,9
Waveform Distors.(THD) no load LL/LN		%	2,8 / 2,7	2,7 / 2,6	2,6 / 2,8	2 / 2,1	2,6 / 2,8	2,7 / 2,7

## Efficiencies @ 50Hz

Models		380V 50Hz					400V 50Hz					415V 50Hz					440V 50Hz				
		0.25	0.5	0.75	1	1.1	0.25	0.5	0.75	1	1.1	0.25	0.5	0.75	1	1.1	0.25	0.5	0.75	1	1.1
ECO38 154 A	%	89,1	91,2	92,3	92,3	92,1	88,9	91,3	92,6	92,4	92,1	88,7	91,3	92,5	92,1	91,8	88,5	91,1	92,2	91,9	91,5
ECO38 254 A	%	90,1	91,6	92,6	92,6	92,4	89,9	91,7	92,9	92,7	92,4	89,7	91,7	92,8	92,4	92,1	89,5	91,5	92,5	92,2	91,8
ECO38 354 A	%	89,6	91,9	93,0	92,9	92,7	89,4	92,0	93,3	93,0	92,7	89,2	92,0	93,2	92,7	92,4	89,0	91,8	92,9	92,5	92,1
ECO38 1L4 A	%	90,1	92,3	93,4	93,3	93,1	89,9	92,4	93,7	93,4	93,1	89,7	92,4	93,6	93,1	92,8	89,5	92,2	93,3	92,9	92,5
ECO38 2L4 A	%	90,2	92,7	93,8	93,5	93,3	89,9	92,7	94,0	93,7	93,4	89,7	92,7	93,9	93,4	93,1	89,5	92,5	93,6	93,2	92,8
ECO38 3L4 A	%	90,1	92,5	93,4	93,4	93,2	89,9	92,6	93,7	93,5	93,2	89,7	92,6	93,6	93,2	92,9	89,5	92,4	93,3	93,0	92,6

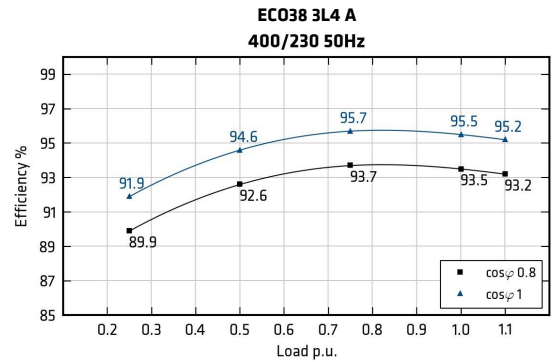
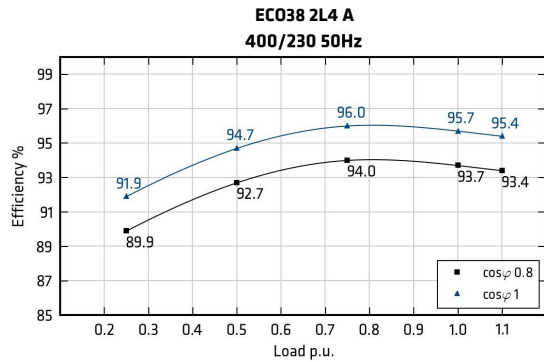
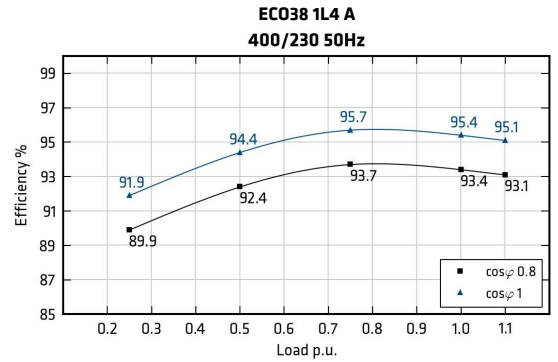
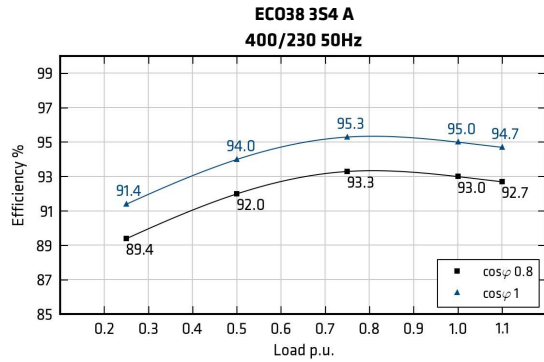
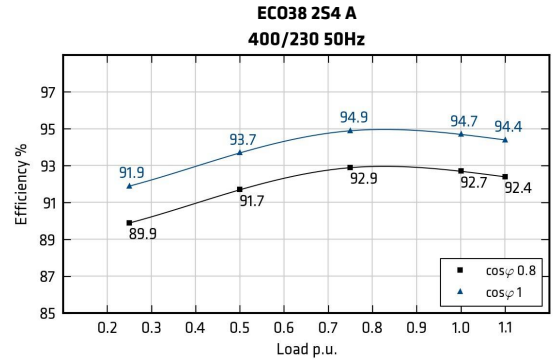
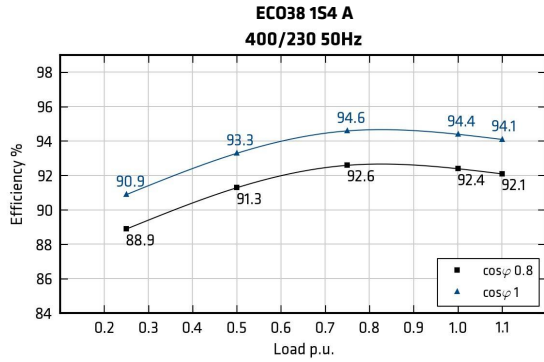

Efficiencies @ 60Hz

Models		415V 60Hz					440V 60Hz					460V 60Hz					480V 60Hz				
		0.25	0.5	0.75	1	1.1	0.25	0.5	0.75	1	1.1	0.25	0.5	0.75	1	1.1	0.25	0.5	0.75	1	1.1
ECO38 154 A	%	90,1	92,0	93,0	92,7	92,4	90,1	92,1	93,2	93,2	93,0	90,1	92,2	93,4	93,3	93,2	89,9	92,3	93,6	93,4	93,2
ECO38 254 A	%	90,6	92,5	93,4	93,1	92,8	90,6	92,6	93,6	93,6	93,4	90,6	92,7	93,8	93,7	93,6	90,4	92,8	94,0	93,8	93,6
ECO38 354 A	%	90,6	93,1	93,9	93,5	93,2	90,6	93,2	94,1	94,0	93,8	90,6	93,3	94,3	94,1	94,0	90,4	93,4	94,5	94,2	94,0
ECO38 1L4 A	%	90,6	93,4	94,3	93,8	93,5	90,6	93,5	94,5	94,3	94,1	90,6	93,6	94,7	94,4	94,2	90,4	93,7	94,9	94,5	94,1
ECO38 2L4 A	%	90,6	93,6	94,5	94,0	93,7	90,6	93,7	94,7	94,5	94,3	90,6	93,8	94,9	94,6	94,4	90,4	93,9	95,1	94,7	94,3
ECO38 3L4 A	%	90,6	93,0	93,9	93,6	93,3	90,6	93,1	94,1	94,1	93,9	90,6	93,2	94,3	94,2	94,0	90,4	93,3	94,5	94,3	93,9

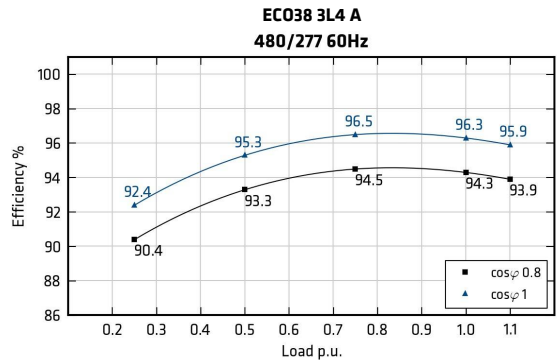
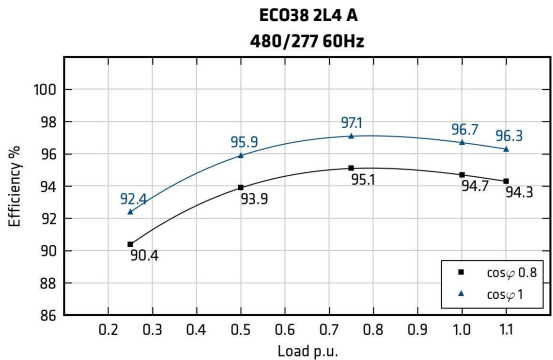
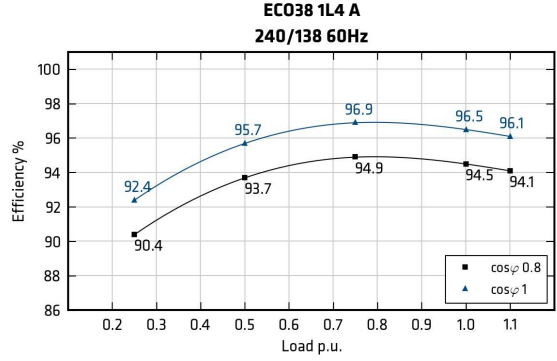
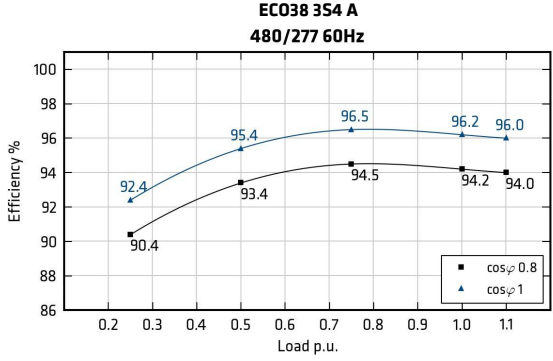
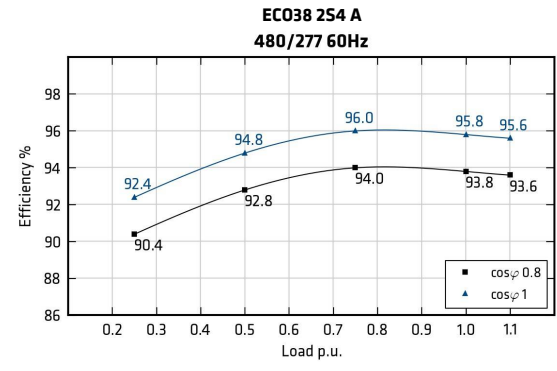
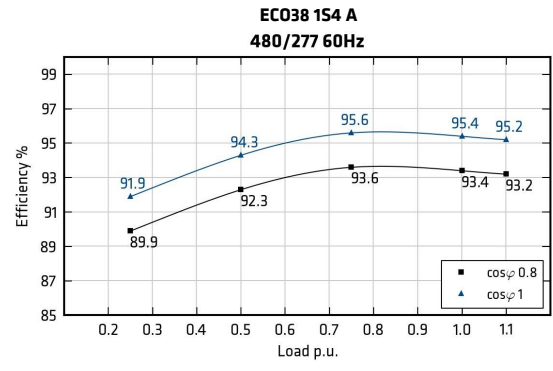

Transients voltage

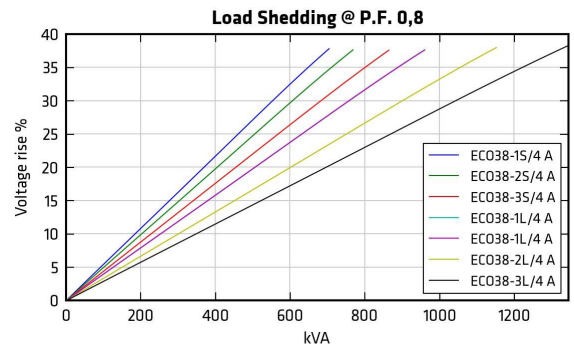
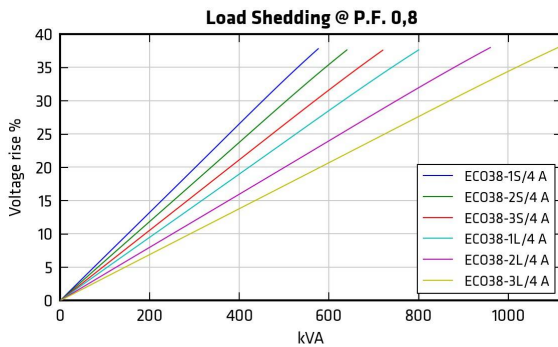
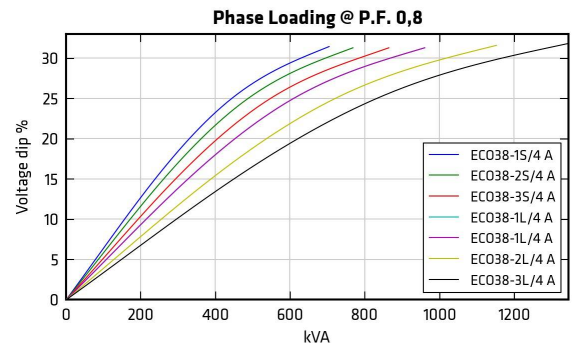
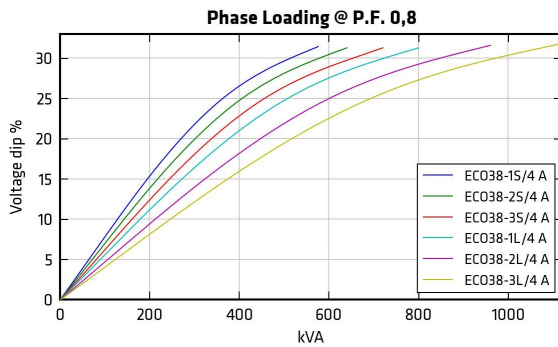
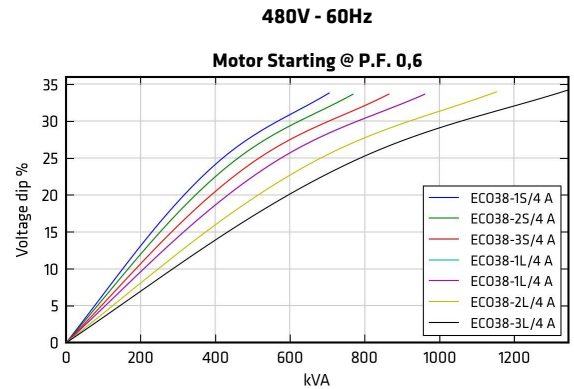
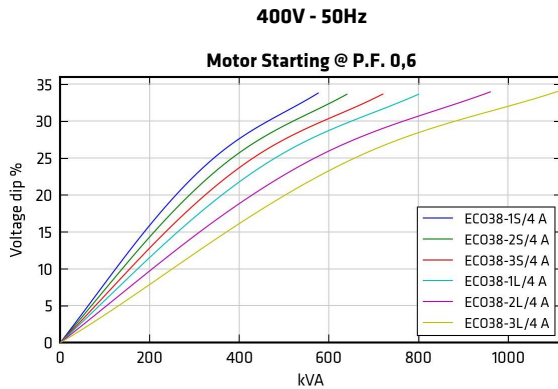

In order to scale transient curves as a function of a power factor or voltage if not indicated, please proceed as follows:

Power Factor coefficient corrector (PFCC), to be used on power factor 0.6 curves:

$$PFCC = \frac{\sin(\text{ARCCos}(PF_{\text{new}}))}{0.8}$$

Example. The PFCC at power factor 0.3 is 1.192 [  $PFCC = \frac{\sin(\text{ARCCos}(0.3))}{0.8}$  ]. This means that the voltage fall at a given power at pf 0.3 is equivalent to the one that can be read on the pf 0.6 curve if the load is considered 1.192 times bigger (19% higher value. ).

In this example, a 100 kVA load insertion at pf 0.3 is equivalent in voltage fall to a 119kVA load insertion at pf 0.6.

Voltage coefficient corrector (VCC):

$$VCC = \left(\frac{400}{V_{\text{new}}}\right)^2 \text{ if } 50 \text{ Hz}; \quad VCC = \left(\frac{480}{V_{\text{new}}}\right)^2 \text{ if } 60 \text{ Hz}$$

Example. VCC at 415V 60 Hz is 1.338 [  $VCC = \left(\frac{480}{415}\right)^2$  ]. This means that the voltage fall at a given power at 415V is equivalent to the one that can be read on the power factor 0.6 curve if the load is considered 1.338 times bigger (33% higher value. ).

In this example, a 100 kVA load insertion at 415V is equivalent in voltage fall to a 133kVA load insertion at 480V.

50Hz Short circuit decrement curves - No load excitation at rated speed

ECO38 1S4 A

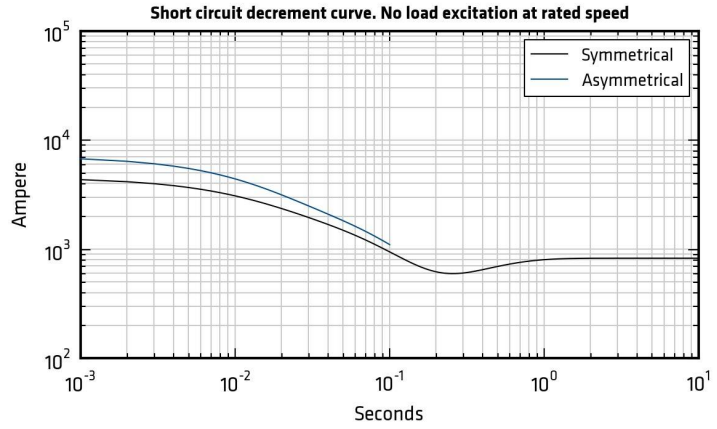

ECO38 2S4 A

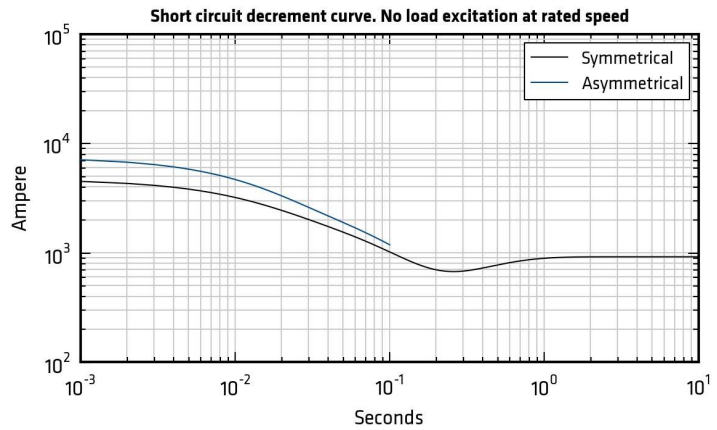

ECO38 3S4 A

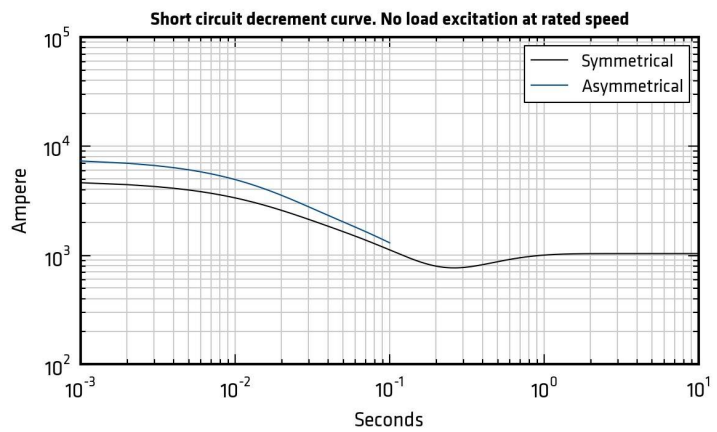

ECO38 1L4 A

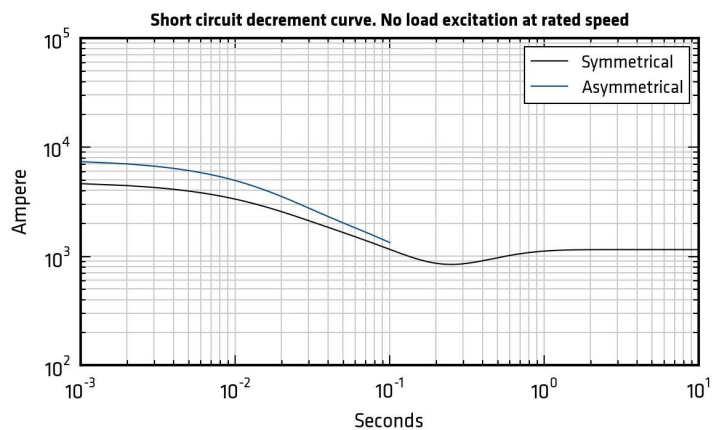

\*Please refer to tables at page 6

50Hz Short circuit decrement curves - No load excitation at rated speed

ECO38 2L4 A

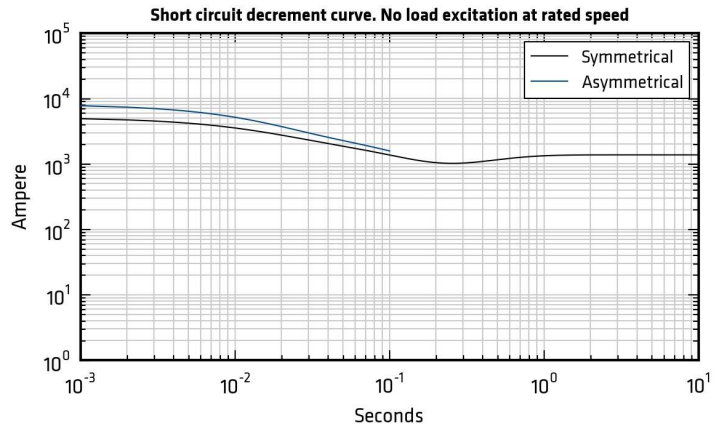

ECO38 3L4 A

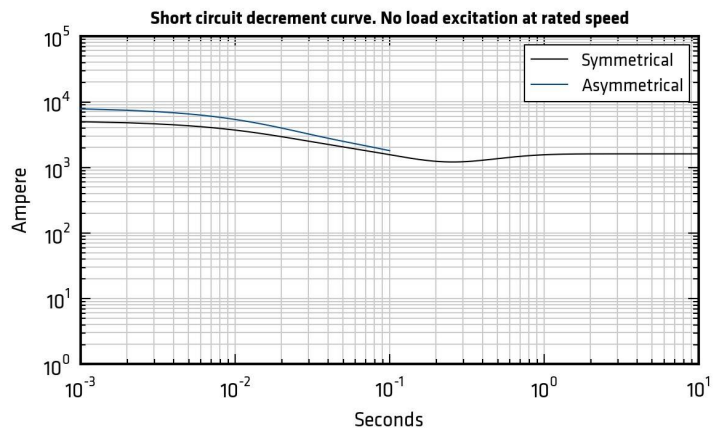

\*Please refer to tables at page 6

60Hz Short circuit decrement curves - No load excitation at rated speed

ECO38 1S4 A

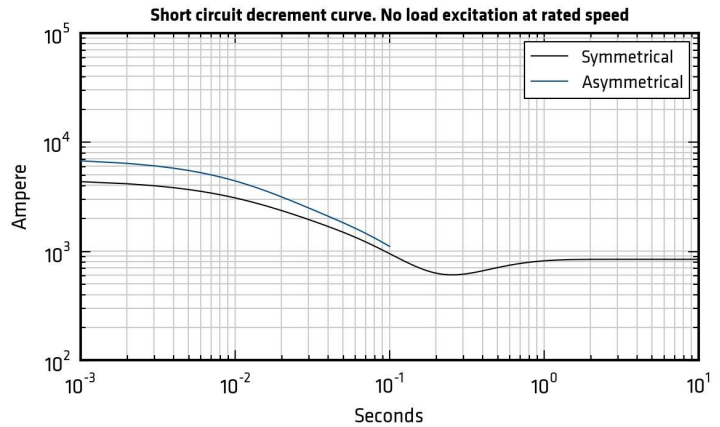

ECO38 2S4 A

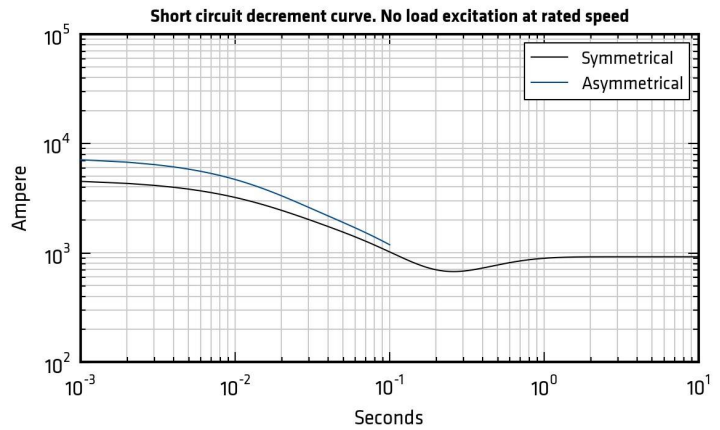

ECO38 3S4 A

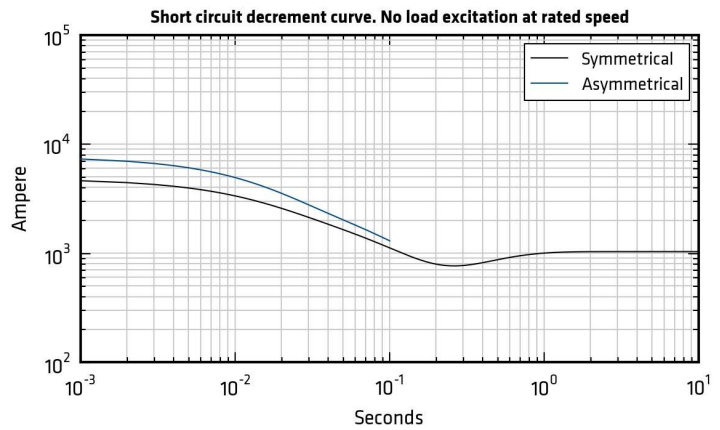

ECO38 1L4 A

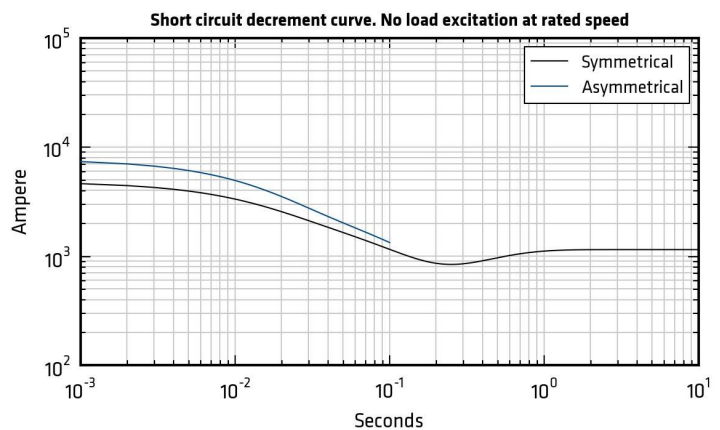

\*Please refer to tables at page 6

60Hz Short circuit decrement curves - No load excitation at rated speed

ECO38 2L4 A

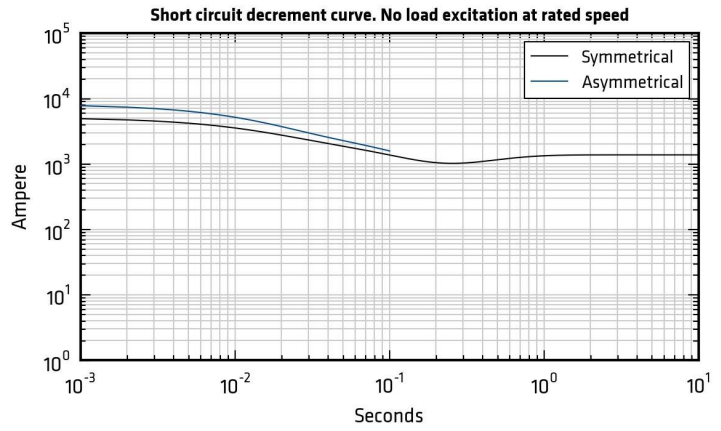

ECO38 3L4 A

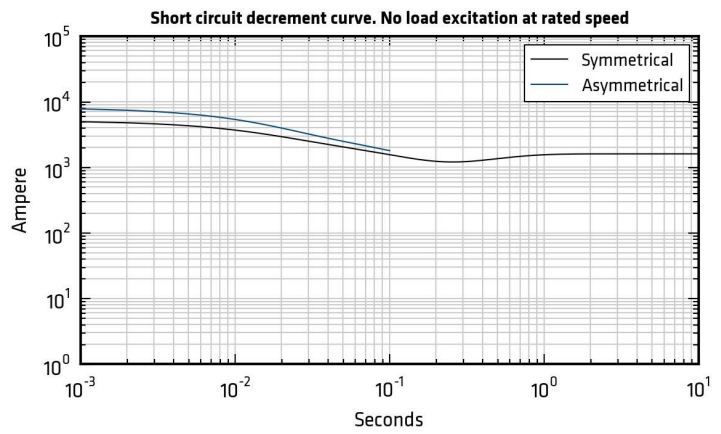

\*Please refer to tables at page 6



## Additional Characteristics

Data	ECO38 1S4 A		ECO38 2S4 A		ECO38 3S4 A		ECO38 1L4 A		ECO38 2L4 A		ECO38 3L4 A		
	50Hz	60Hz	50Hz	60Hz	50Hz	60Hz	50Hz	60Hz	50Hz	60Hz	50Hz	60Hz	
Damper cage	Copper												
Stator Winding Resistance (20°C)	Ω	0,013		0,0105		0,008		0,0065		0,006		0,004	
Rotor Winding Resistance (20°C)	Ω	3,905		4,133		4,449		4,887		5,604		6,78	
Stator Exciter Resistance (20°C)	Ω	15,28		15,28		15,28		15,28		15,28		15,28	
Rotor Exciter Resistance (20°C)	Ω	0,685		0,685		0,685		0,685		0,685		0,685	
Auxiliary Winding Resistance (20°C)	Ω	0,854		0,845		0,778		0,796		0,751		0,7	
Weight of complete generator	kg	530,0		573,0		602,0		692,0		790,0		930,0	
Unbalanced magnetic pull	kN/mm	4,4		5,2		5,7		5,1		5,9		6,2	
Air flow	m <sup>3</sup> /min	32,0	39,0	32,0	39,0	32,0	39,0	32,0	39,0	32,0	39,0	32,0	39,0
Noise level at 1m/7m	dB(A)	82/69	86/73	82/69	86/73	82/69	86/73	82/69	86/73	82/69	86/73	82/69	86/73

## PQ Diagram

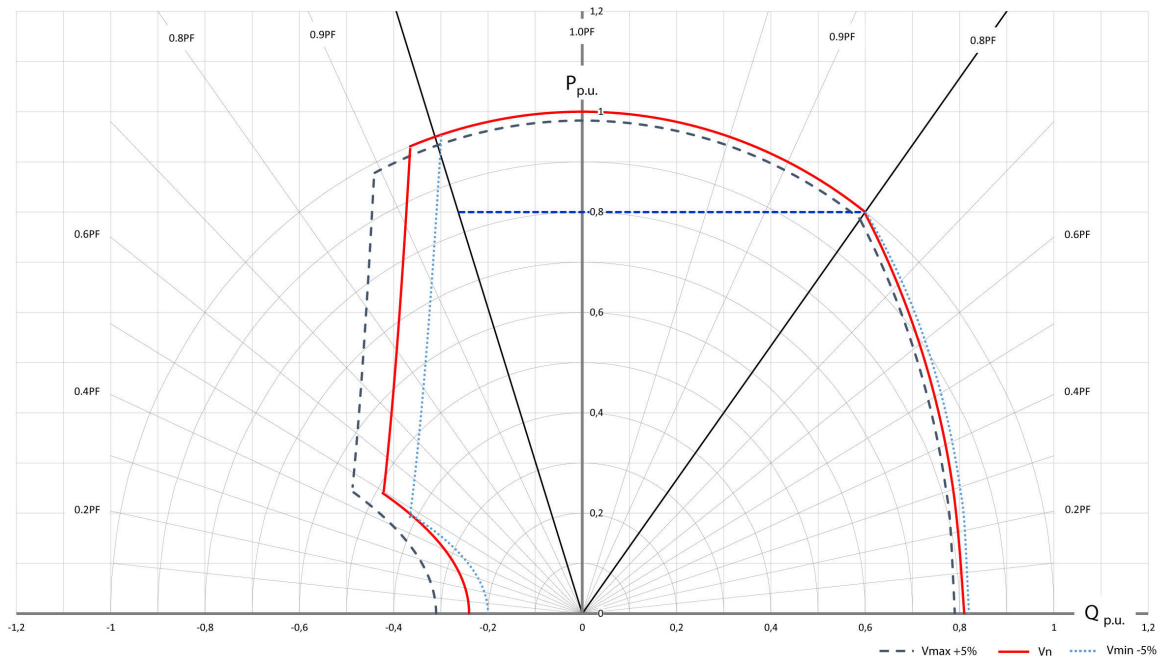

ECO38 1S4 A

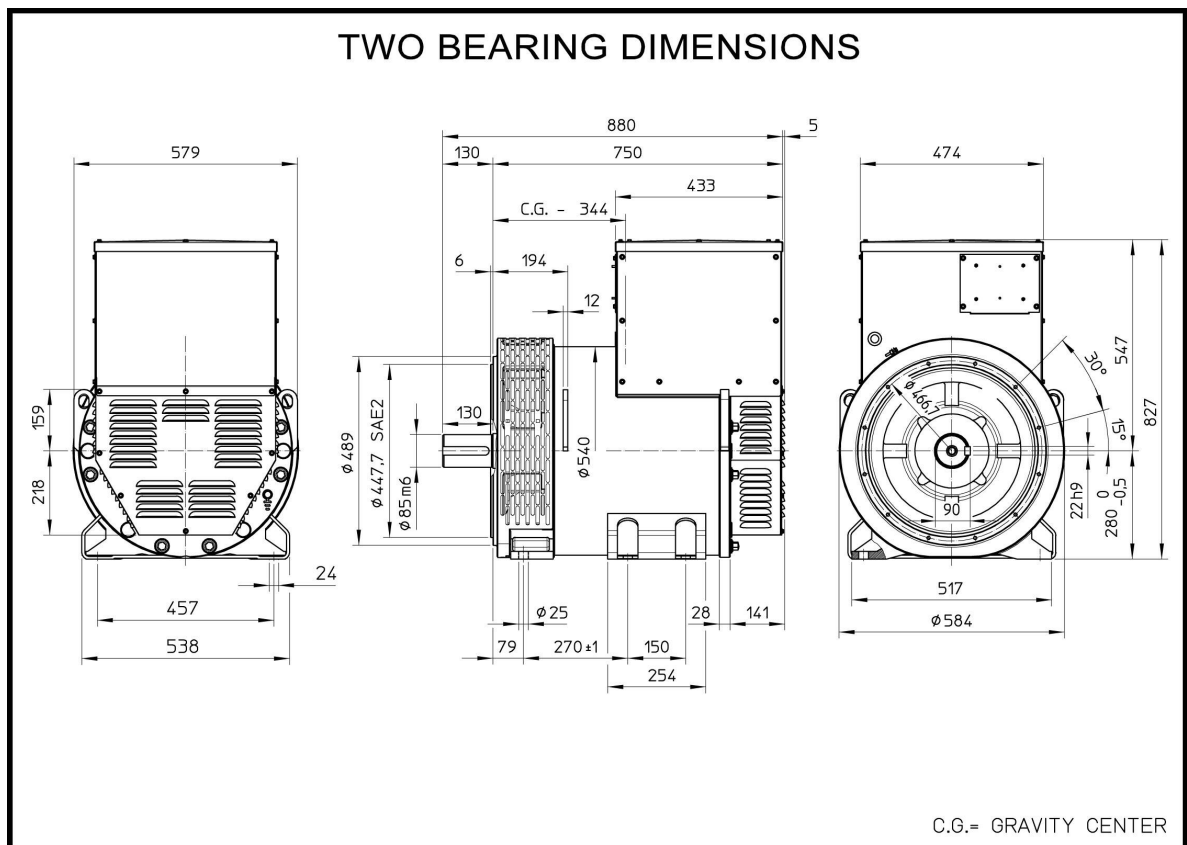
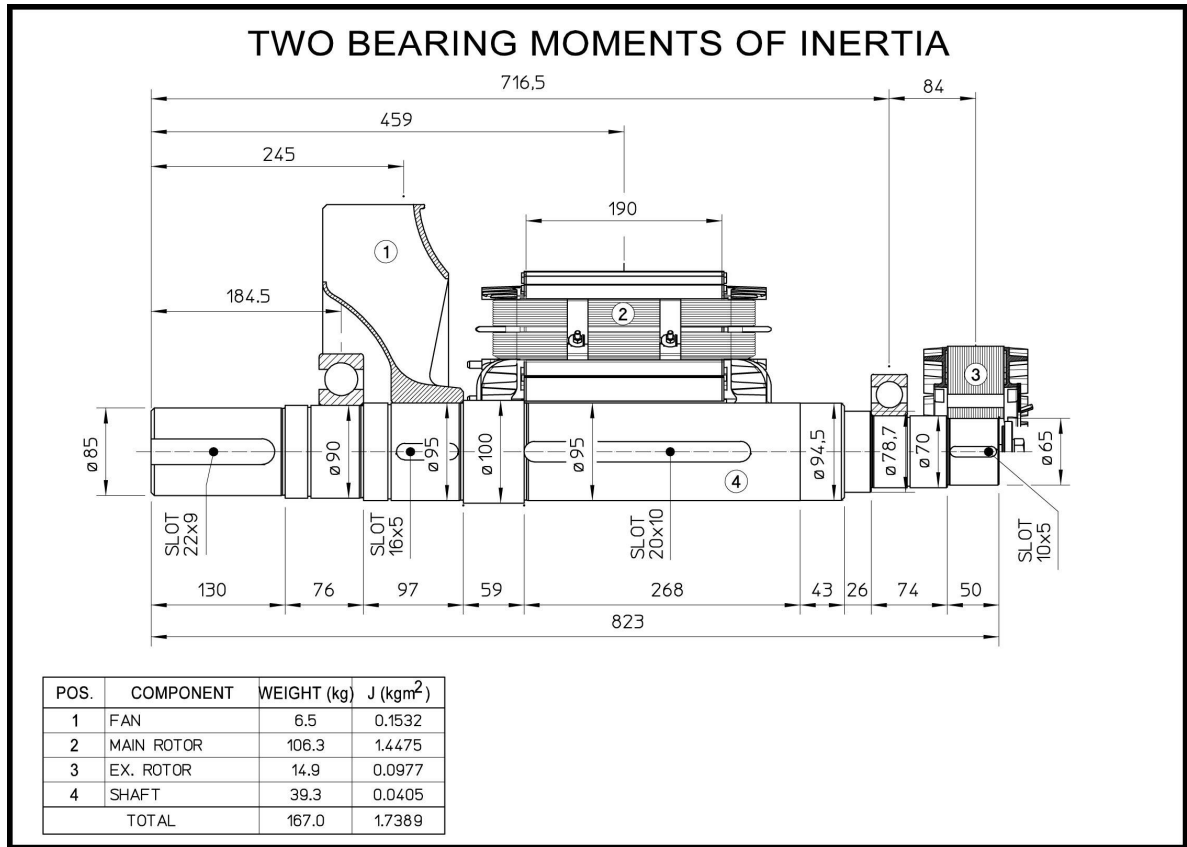

ECO38 1S4 A

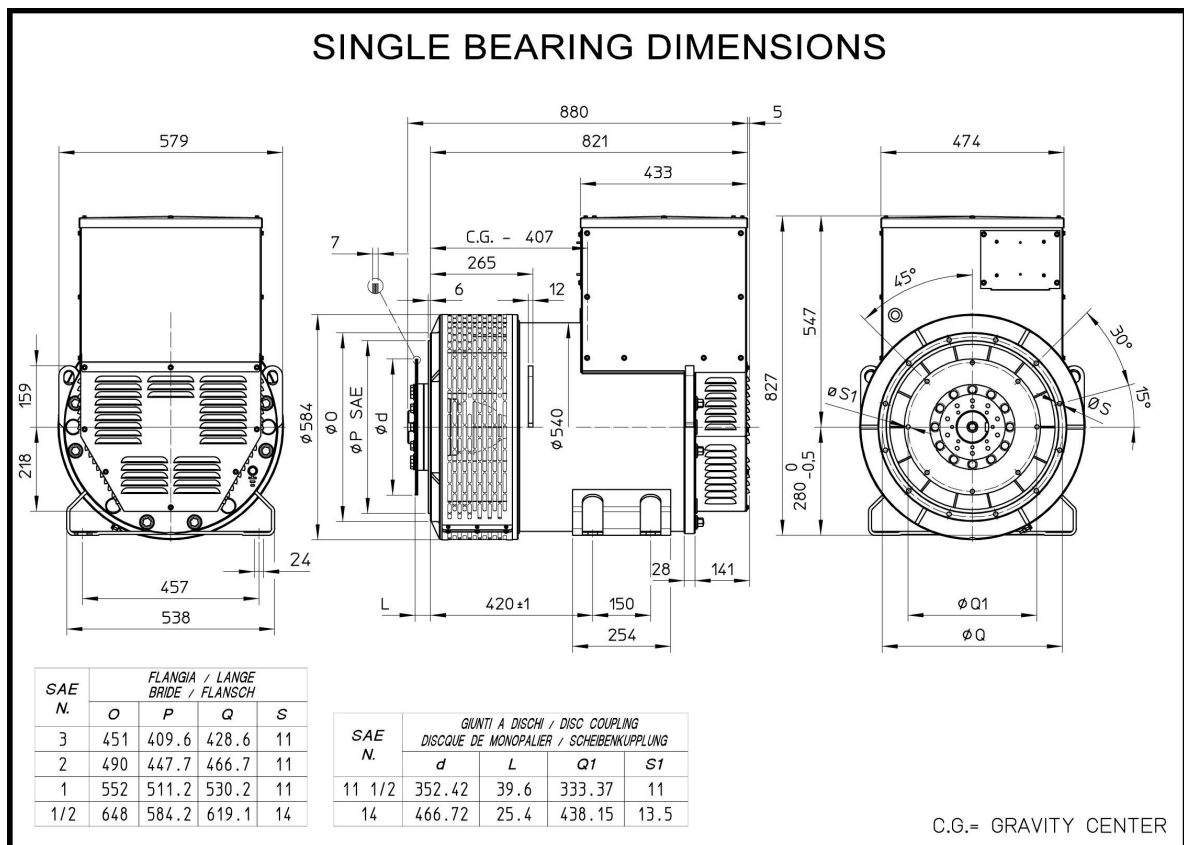
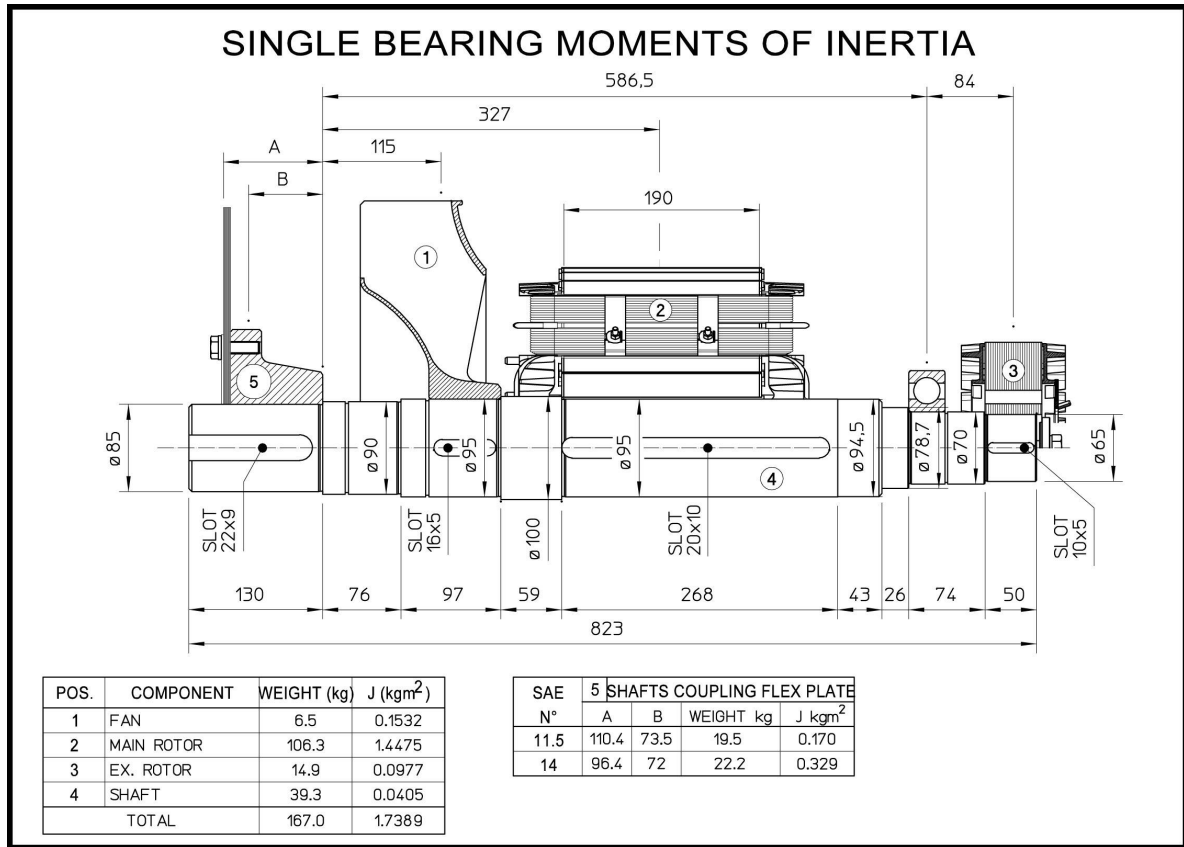

ECO38 2S4 A

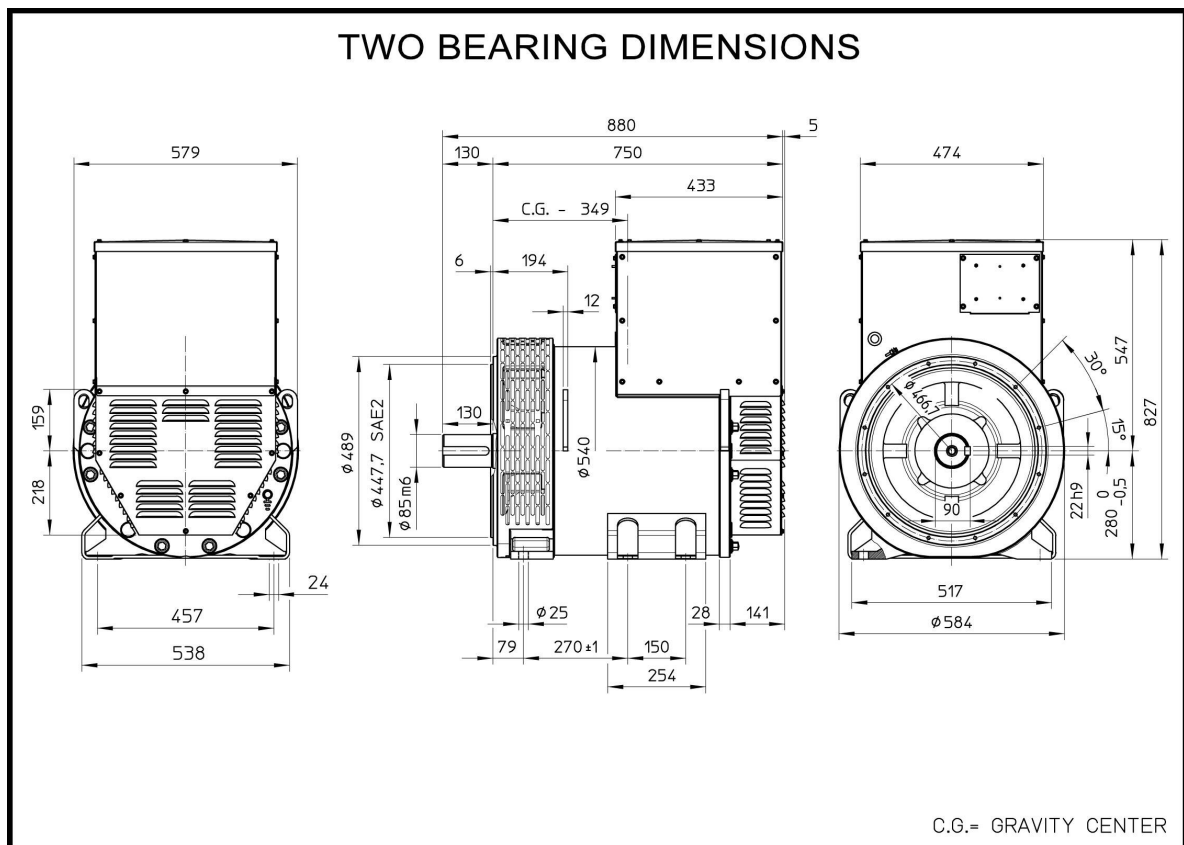
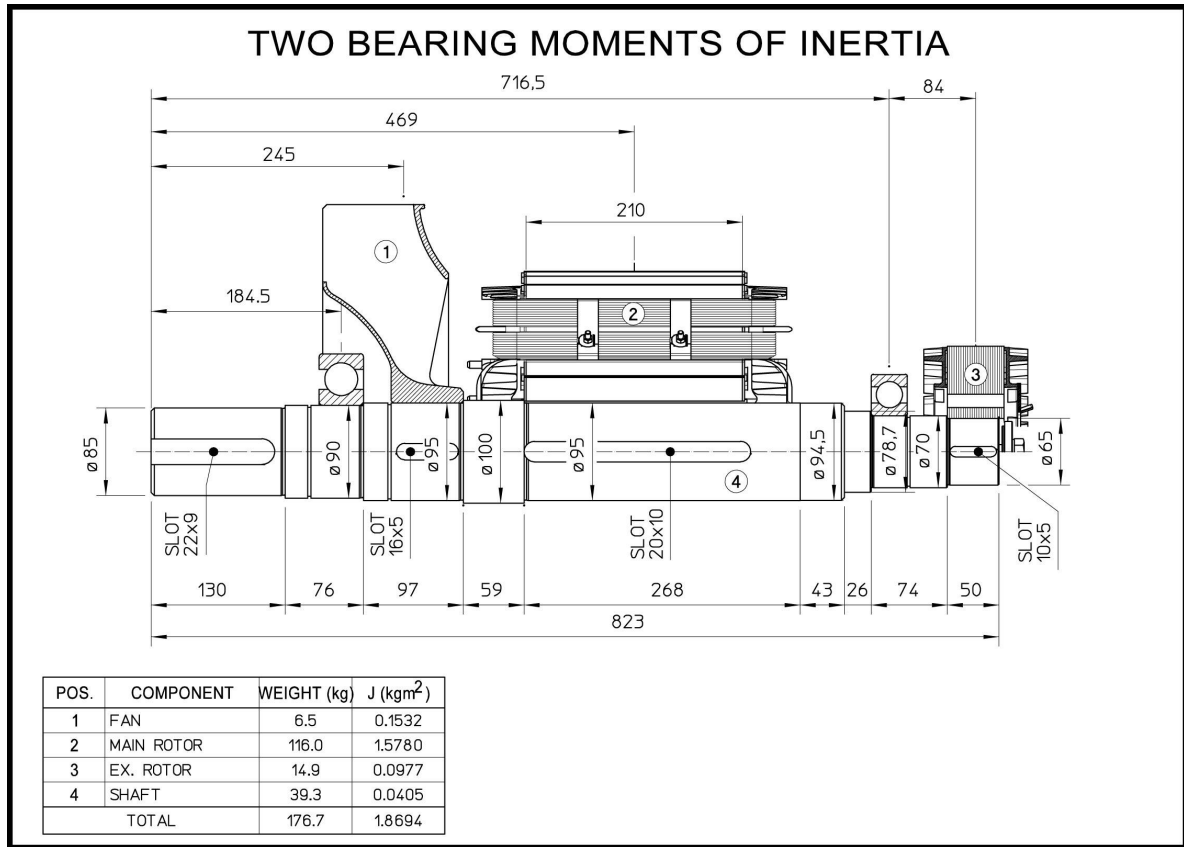

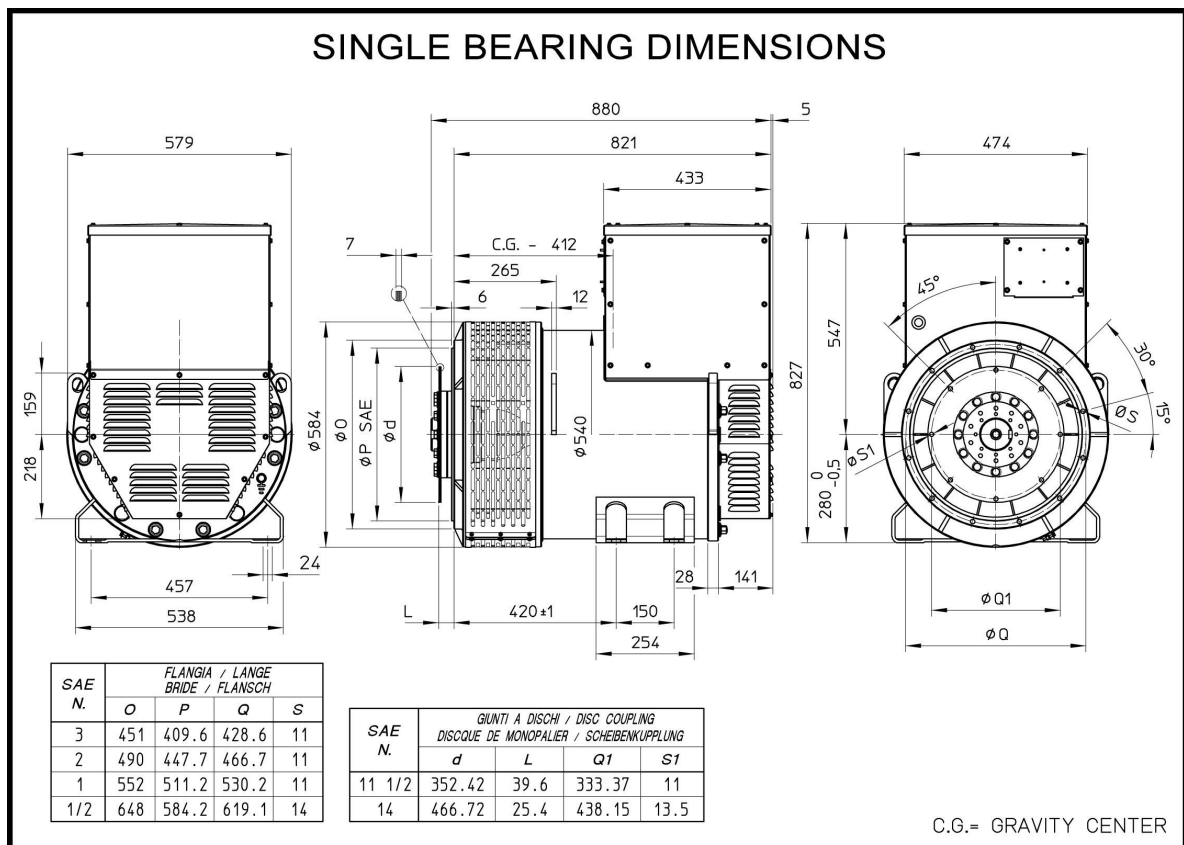
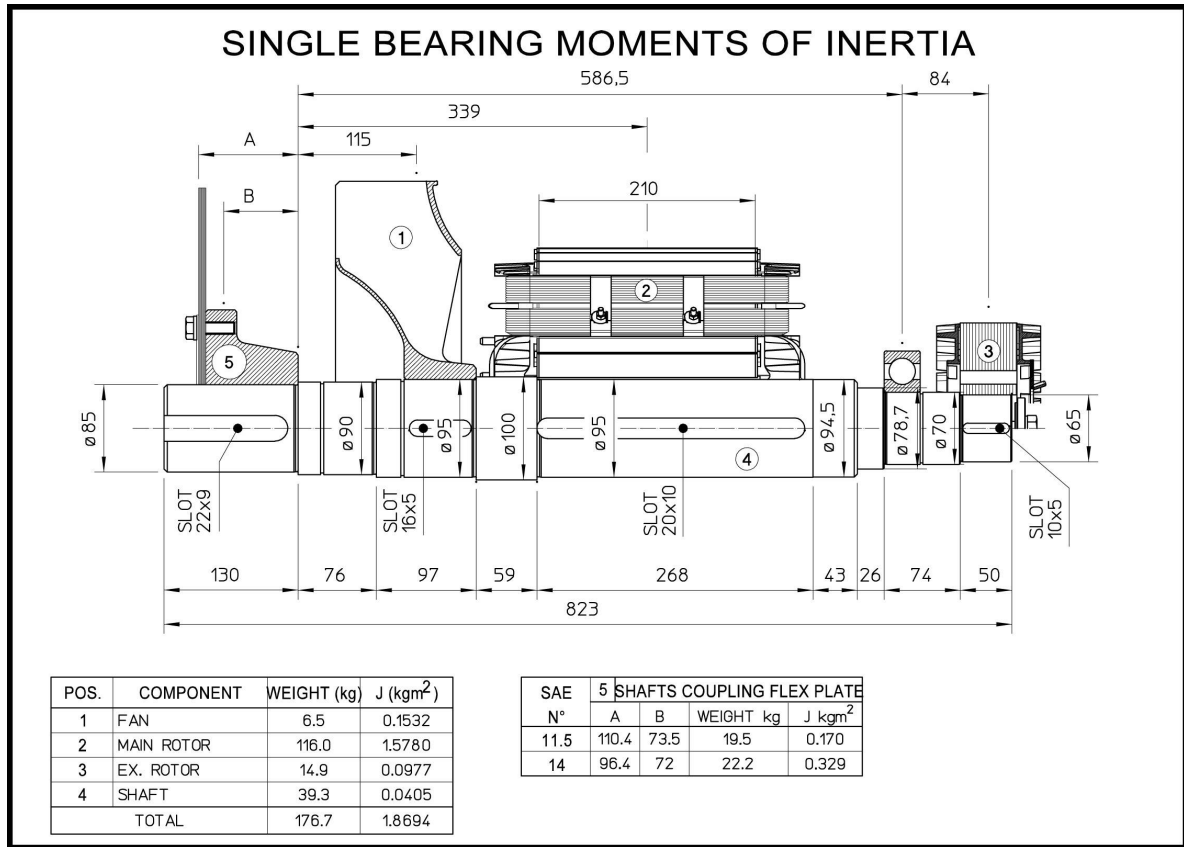

ECO38 3S4 A

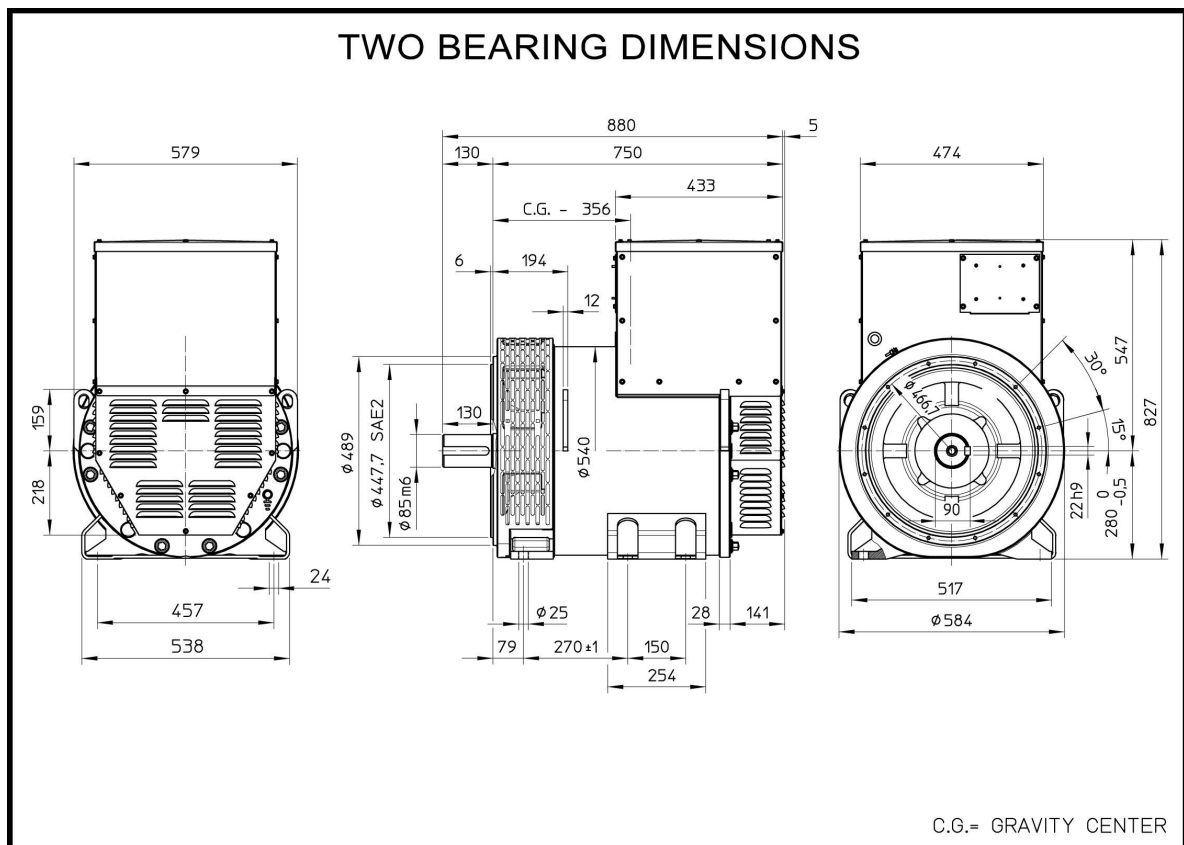
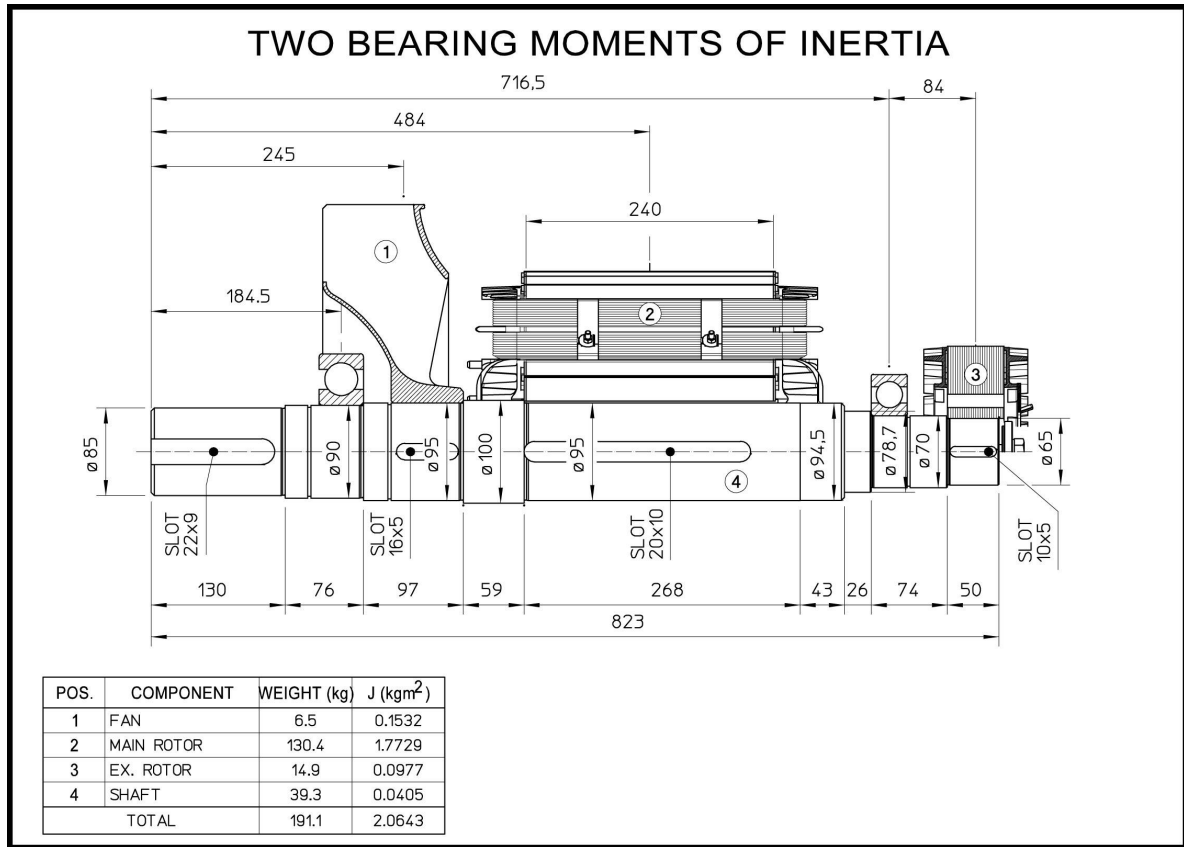

ECO38 3S4 A

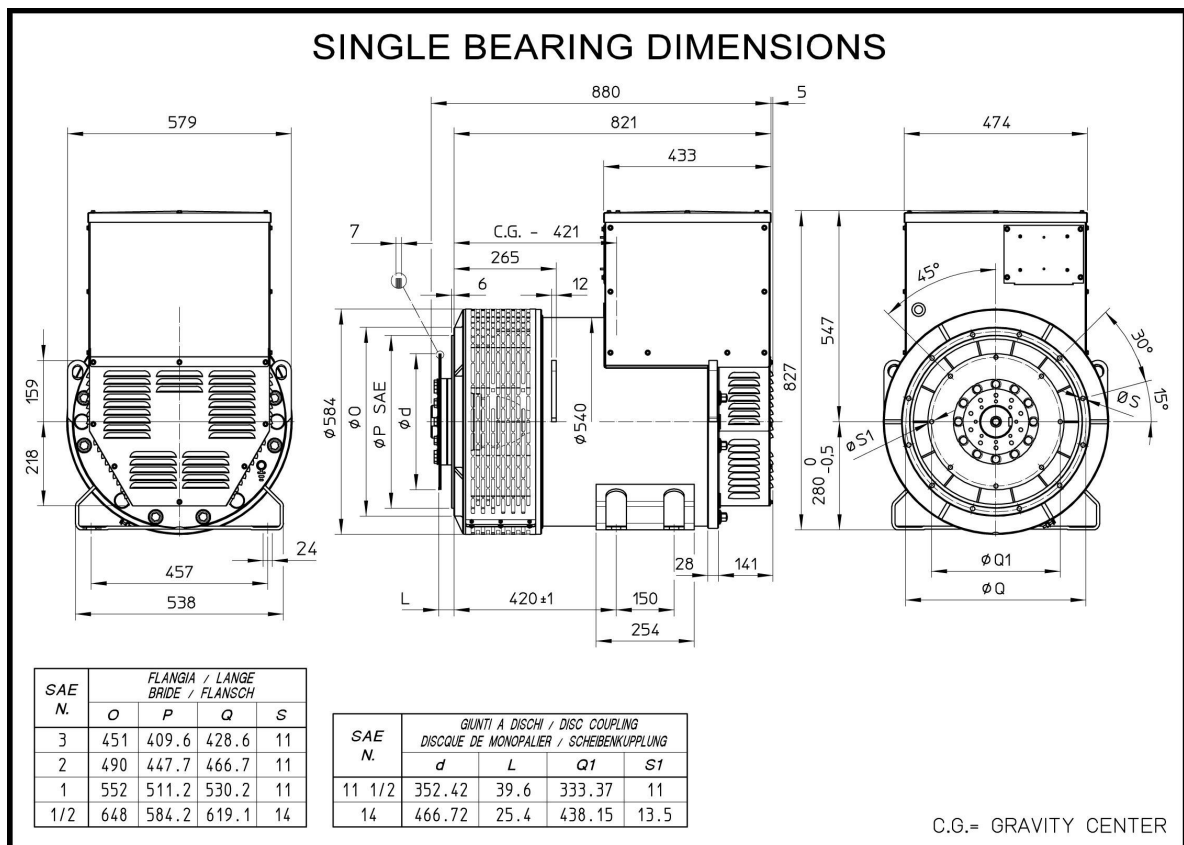
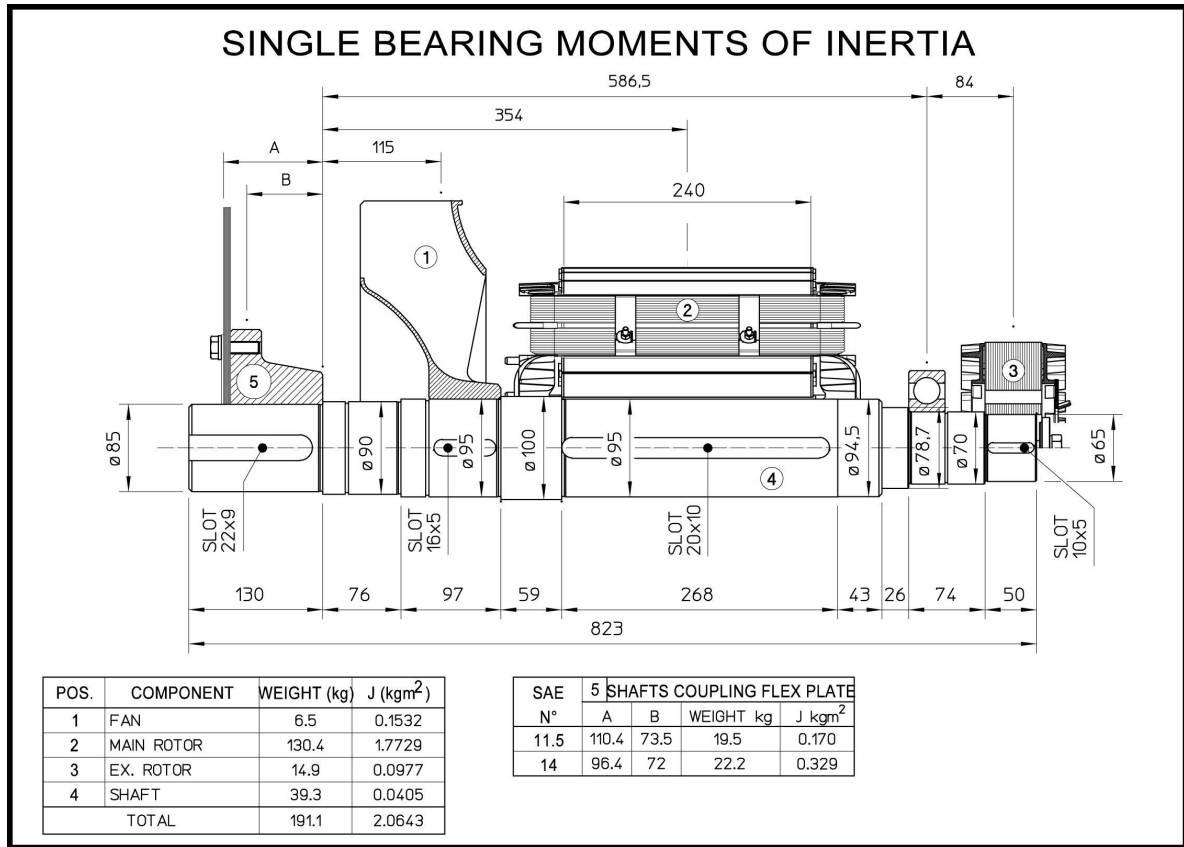

ECO38 1L4 A

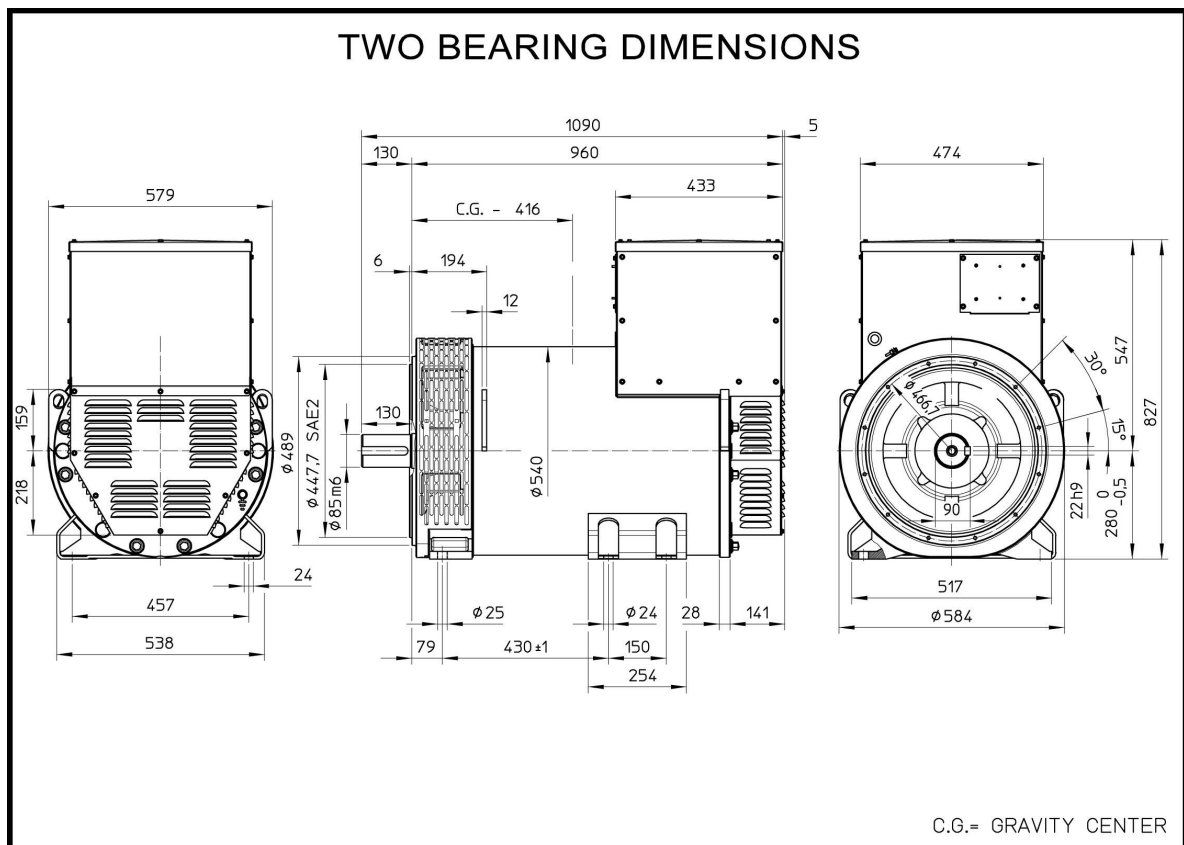
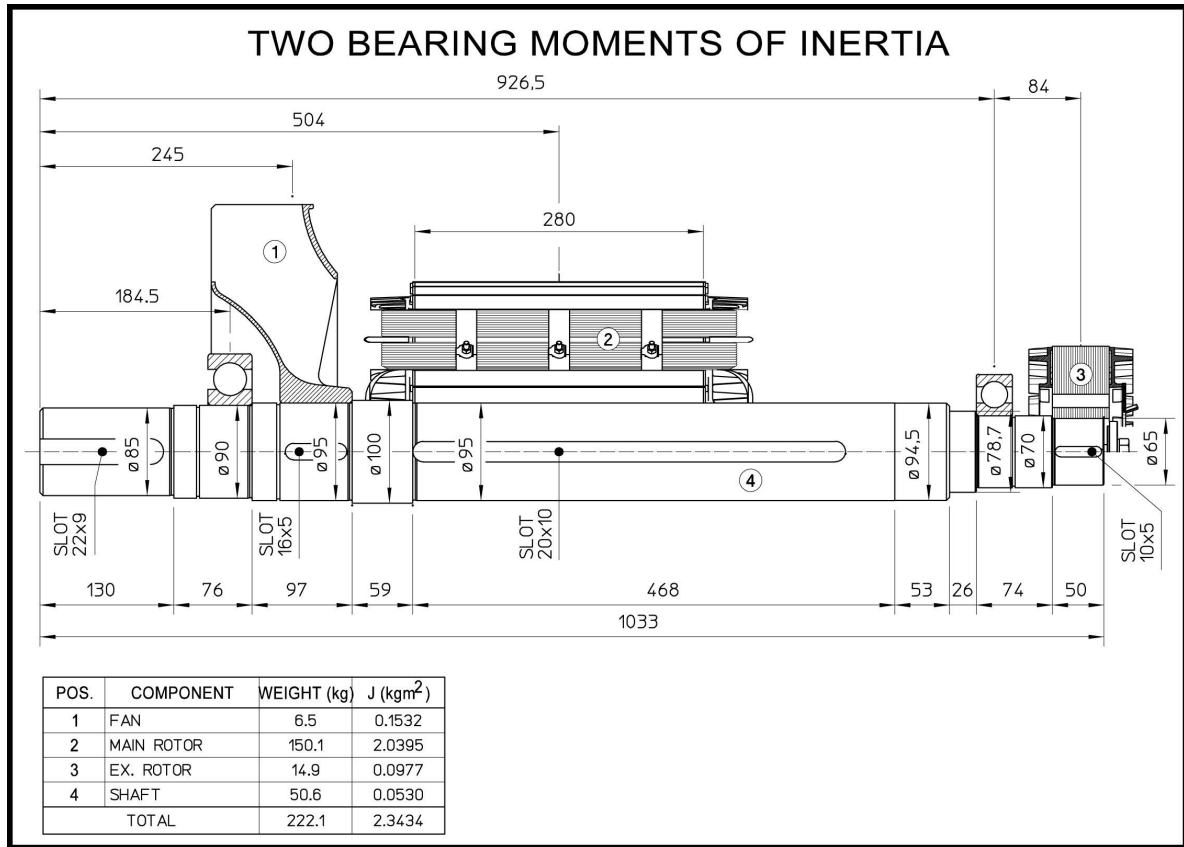





ECO38 2L4 A

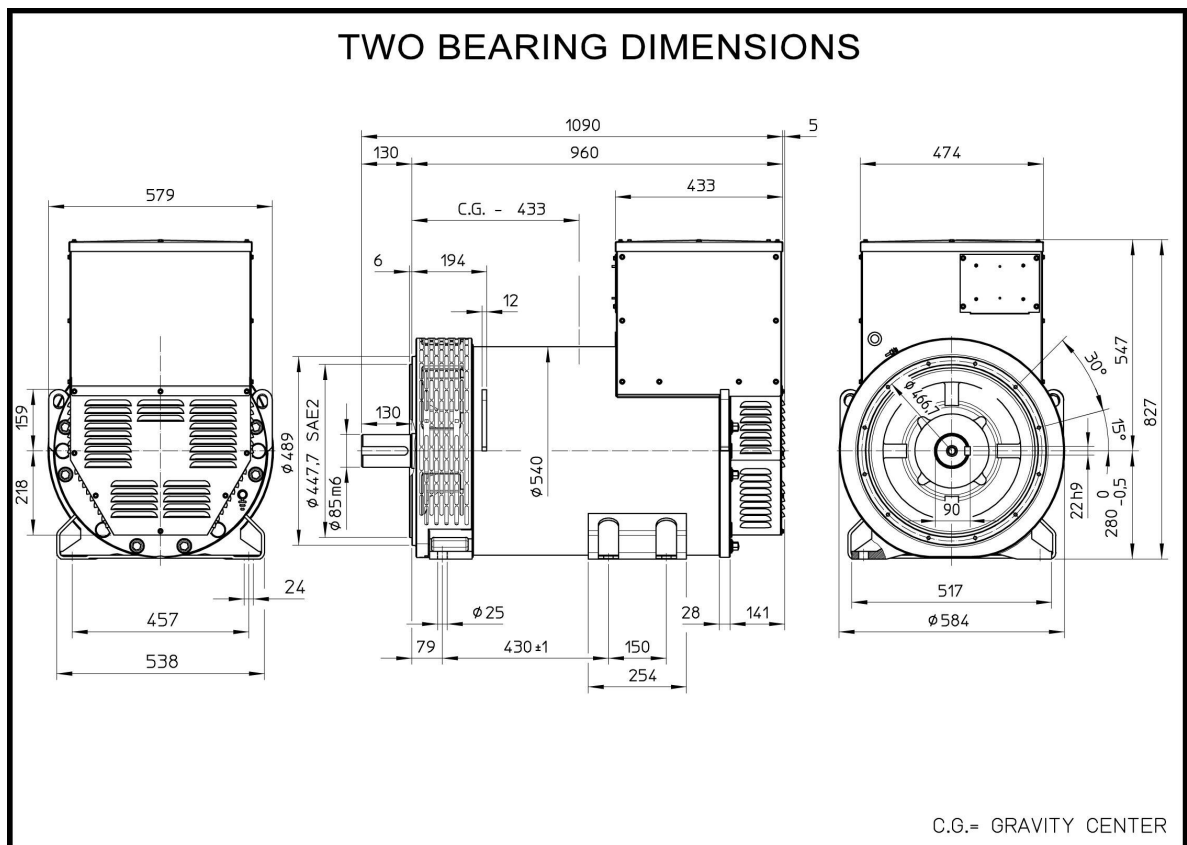
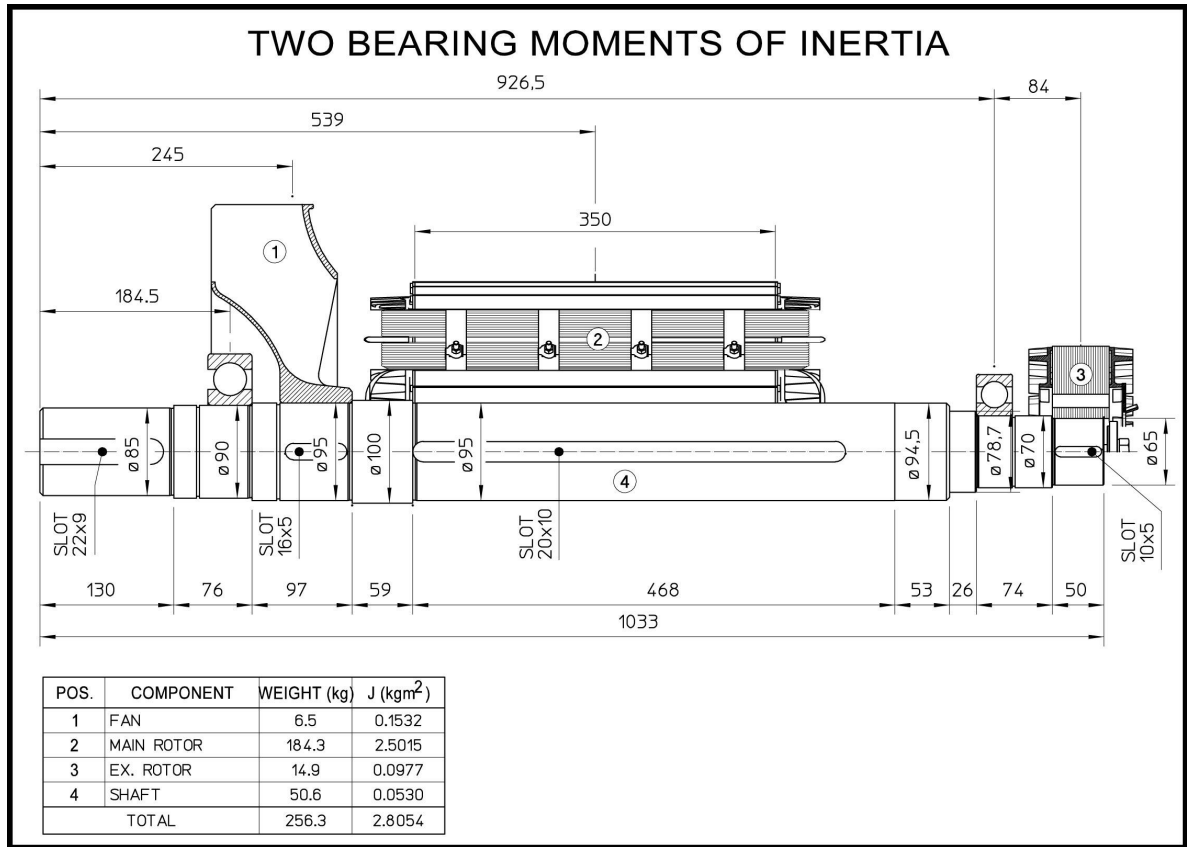

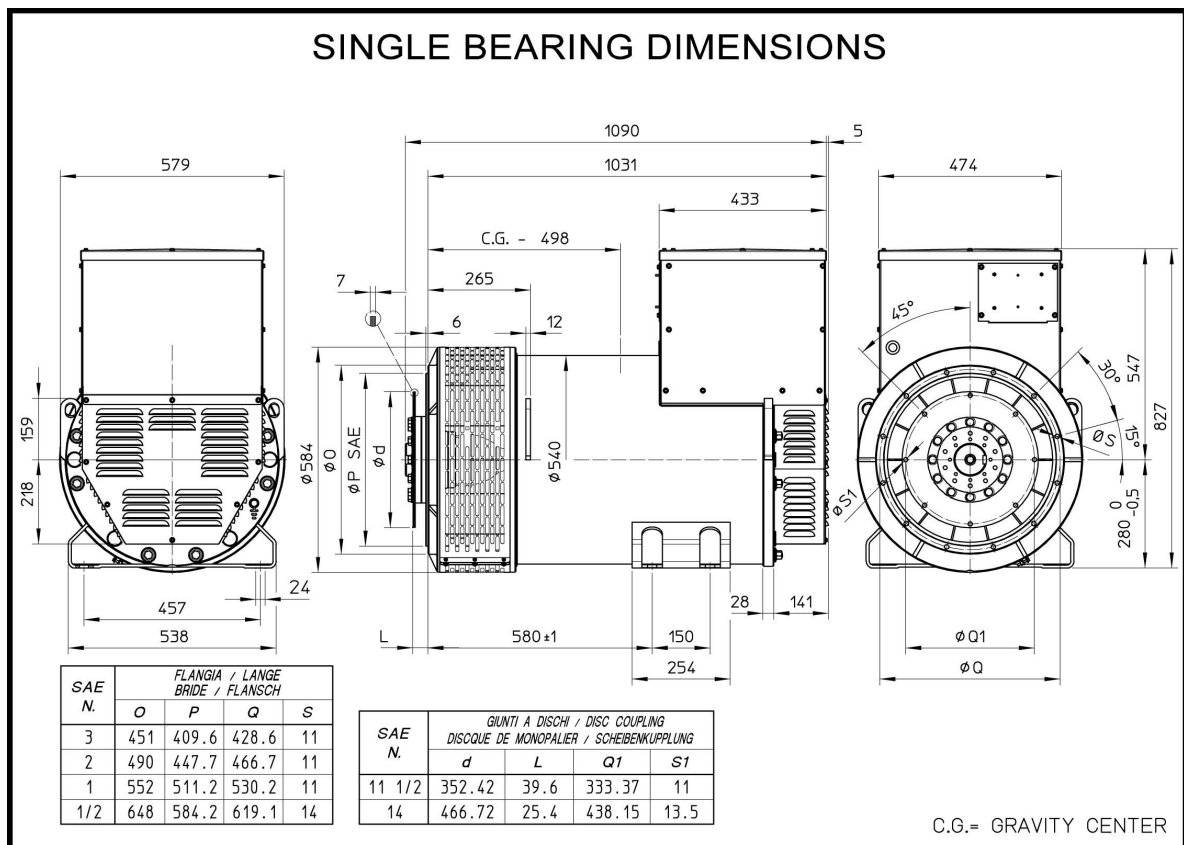
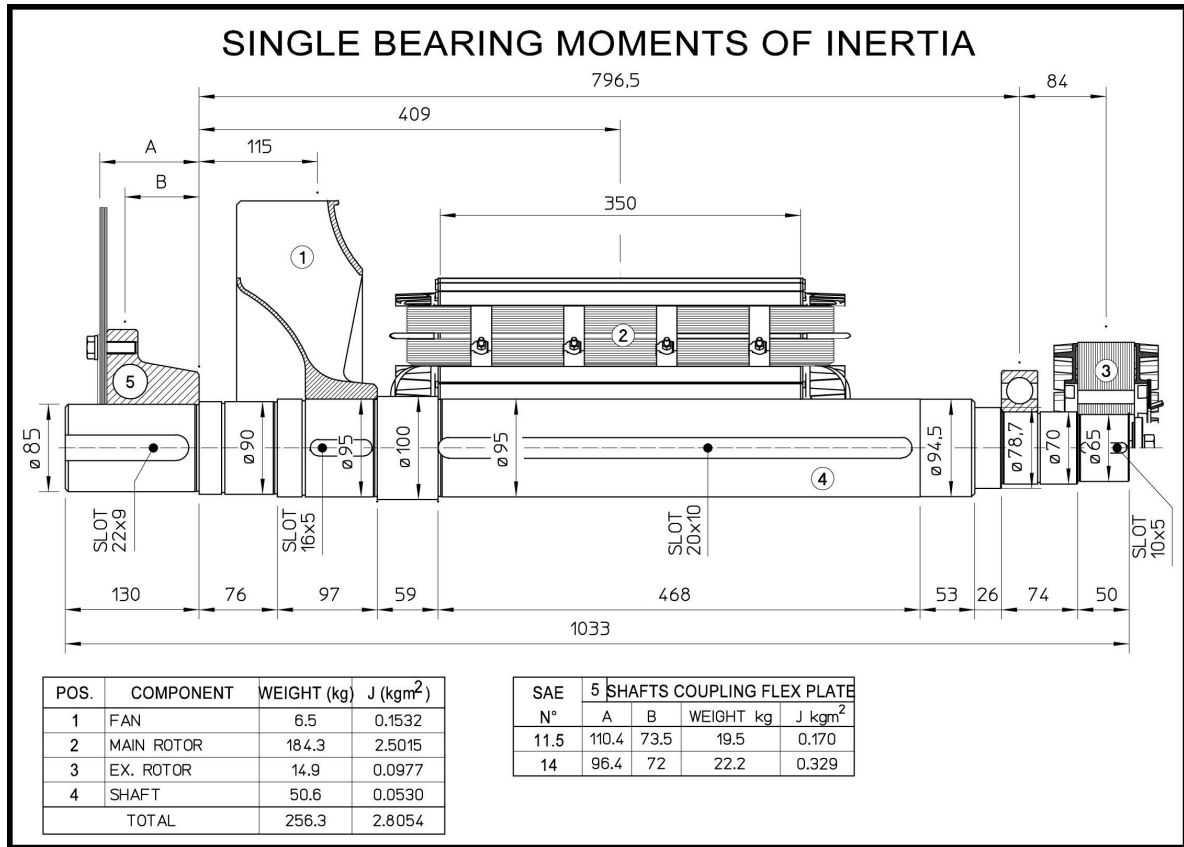

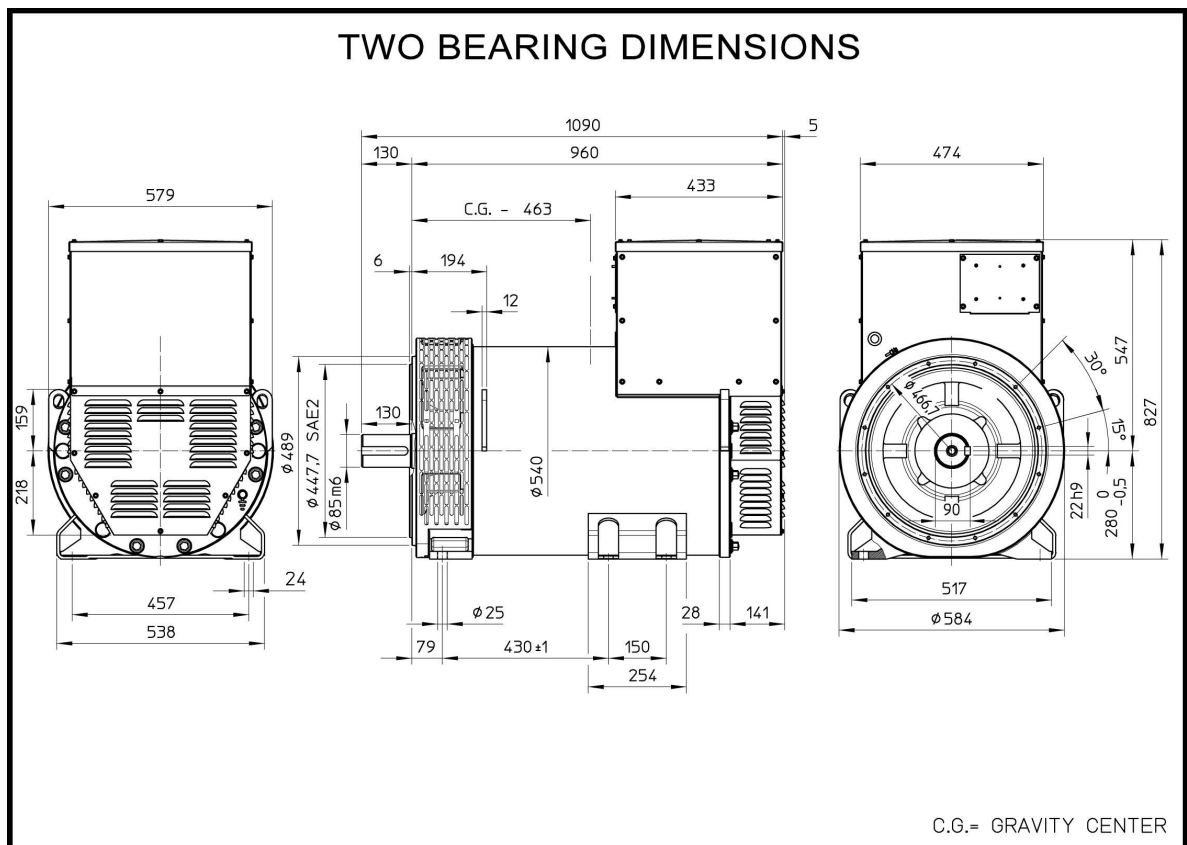
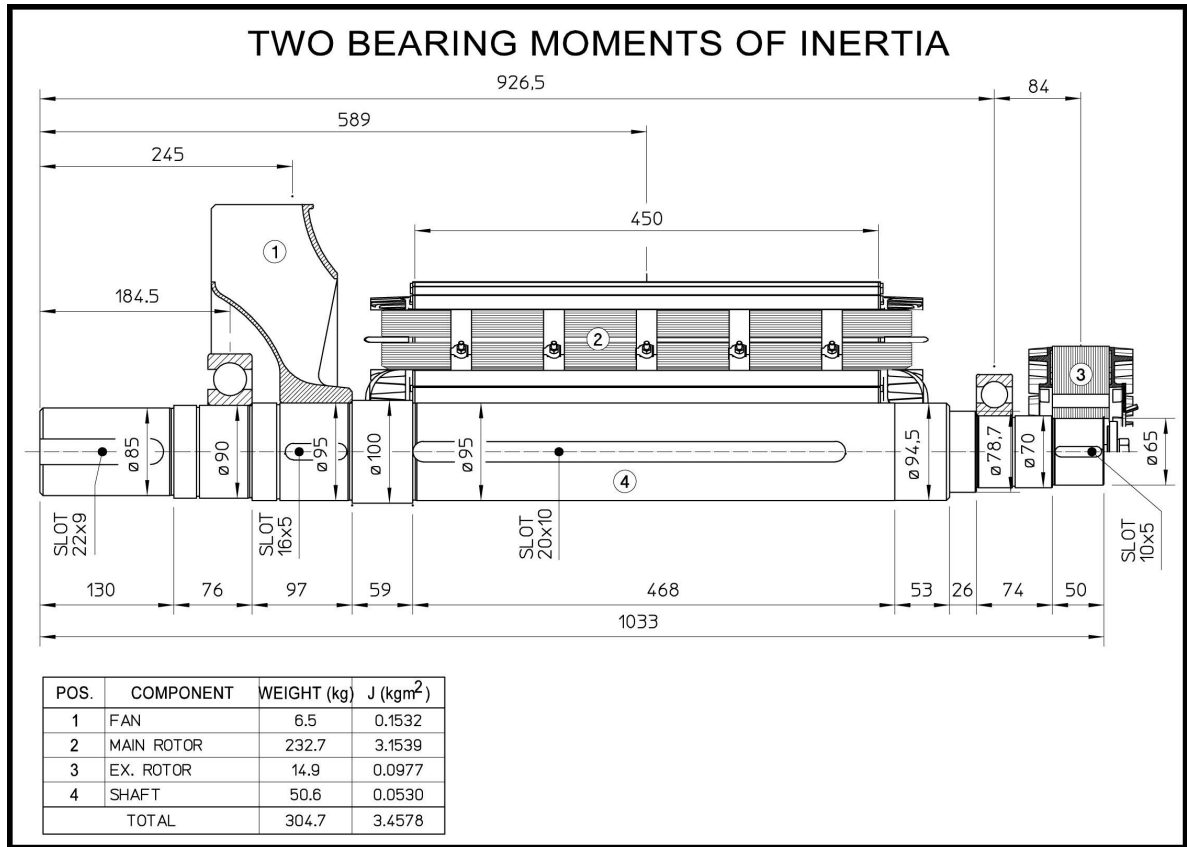

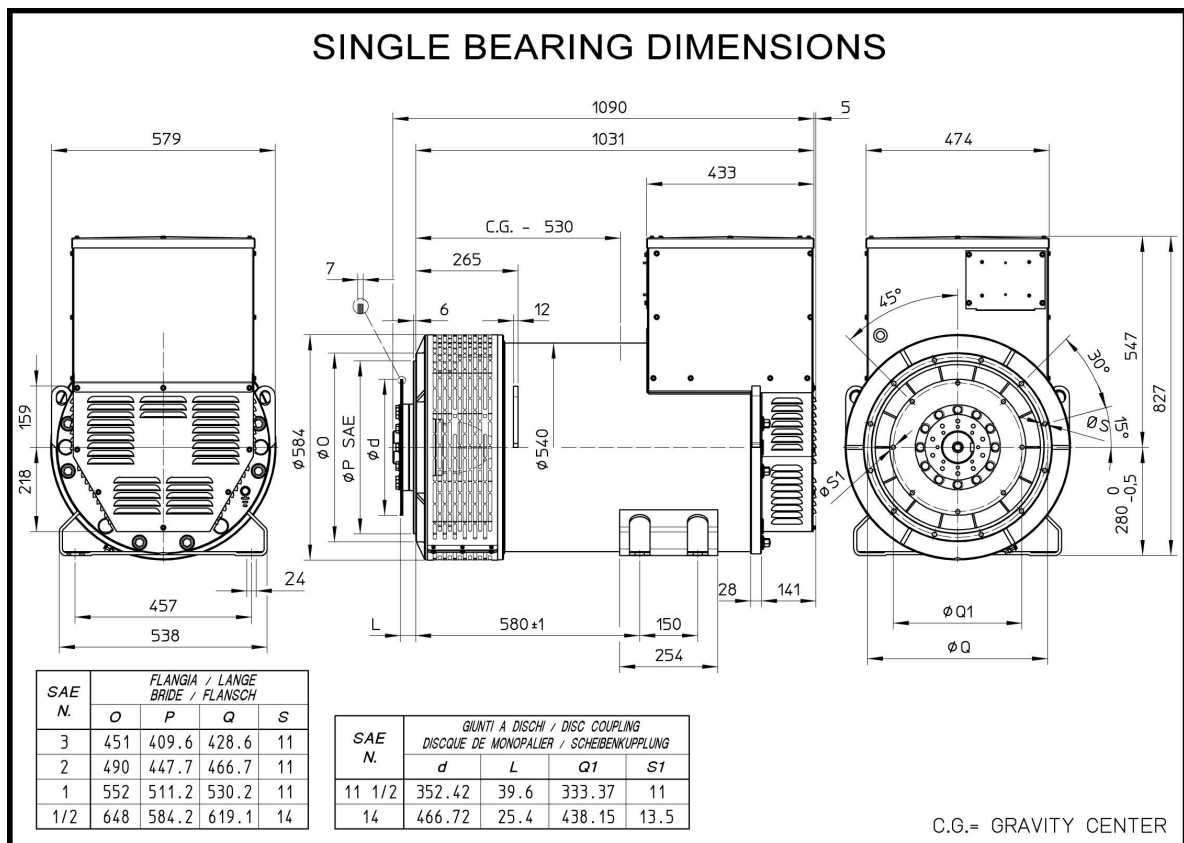
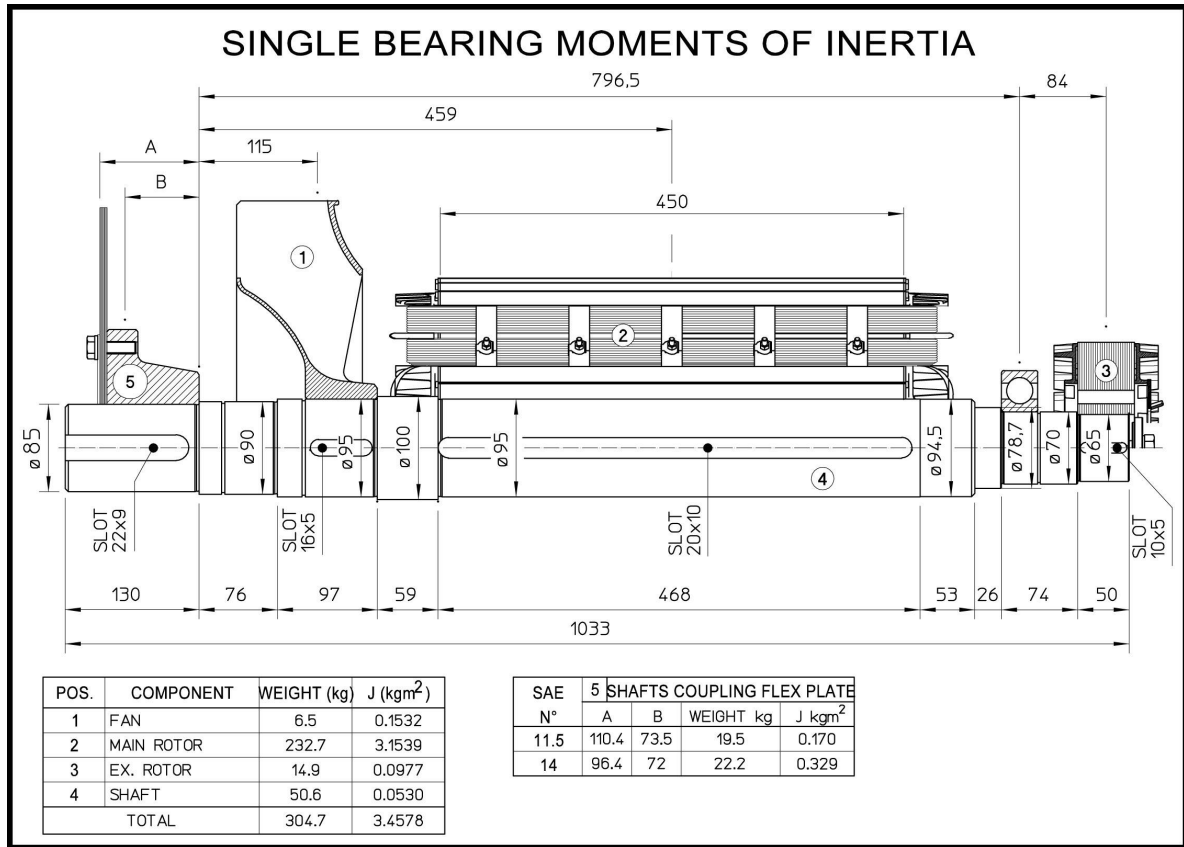





---

**Mecc Alte SpA (HQ)**

Via Roma  
20 - 36051 Creazzo  
Vicenza - ITALY  
T: +39 0444 396111  
E: info@meccalte.it  
aftersales@meccalte.it

---

**Mecc Alte Portable**

Via Roma  
20 - 36051 Creazzo  
Vicenza - ITALY  
T: +39 0444 396111  
E: info@meccalte.it

---

**Mecc Alte Power Products srl**

Via Melaro  
2 - 36075 Montecchio  
Maggiore (VI) - ITALY  
T: +39 0444 1831295  
E: info@meccalte.it

---

**Zanardi Alternatori srl**

Via Dei Laghi  
48/B - 36077 Altavilla  
Vicenza - ITALY  
T: +39 0444 370799  
E: info@zanardialternatori.it

---

**United Kingdom**

Mecc Alte U.K. LTD  
6 Lands' End Way  
Oakham  
Rutland LE15 6RF  
T: +44 (0) 1572 771160  
E: info@meccalte.co.uk

---

**Spain**

Mecc Alte España S.A.  
C/ Rio Taibilla, 2  
Polig. Ind. Los Valeros  
03178 Benijofar (Alicante)  
T: +34 (0) 96 6702152  
E: info@meccalte.es

---

**China**

Mecc Alte Alternator Haimen LTD  
755 Nanghai East Rd  
Jiangsu HEDZ 226100 PRC  
T: +86 (0) 513 82325758  
E: info@meccalte.cn

---

**India**

Mecc Alte India PVT LTD  
Plot NO: 1, Sanaswadi  
Talegaon  
Dhamdhare Road Taluka:  
Shirur, District:  
Pune - 412208  
Maharashtra, India  
T: +91 2137 619600  
E: info@meccalte.in

---

**U.S.A. and Canada**

Mecc Alte Inc.  
1229 Adams Drive  
McHenry, IL, 60051  
T: +1 815 344 0530  
E: info@meccalte.us

---

**Germany**

Mecc Alte Generatoren GmbH  
Bucher Hang 2  
D-87448 Waltenhofen  
T: +49 (0)831 540755 0  
E: info@meccalte.de

---

**Australia**

Mecc Alte Alternators PTY LTD  
10 Duncan Road, PO Box 1046  
Dry Creek, 5094, South  
Australia  
T: +61 (0) 8 8349 8422  
E: info@meccalte.com.au

---

**France**

Mecc Alte International S.A.  
Z.E.La Gagnerie  
16330 ST.Amant de Boixe  
T: +33 (0) 545 397562  
E: info@meccalte.fr

---

**Far East**

Mecc Alte (F.E.) PTE LTD  
19 Kian Teck Drive  
Singapore 628836  
T: +65 62 657122  
E: info@meccalte.com.sg



[www.meccalte.com](http://www.meccalte.com)