



Totally Focused. Totally Independent.

Technical Specification

ECP34 2 A



The world's largest
independent producer of
alternators 1 – 5,000kVA

Standards

Alternators are designed and produced within an ISO 9001 environment. The entire series is manufactured according to, and complies with, the most common specifications such as CEI 2-3, IEC 34-1, EN 60034-1, VDE 0530, BS 4999-5000, NF 51.111, NEMA MG 1-2011, ISO 8528-3. They also comply with other specific standards such as UL1446, UL 1004/4 and /B and CAN/CSA-C22.2 No14-95-No100-95.

Windings and Performances

All windings are 2/3rds pitch to eliminate triplen harmonics within the voltage waveform and to avoid excessive neutral currents in certain parallel operating conditions. A fully interconnected aluminium or copper damper cage is supplied on the rotor of all models (excluding the ECP3 series).

- ▶ 12 wire reconnectable:
50Hz – 380V to 440V and 220/110V to 240/120V (de-rates may apply at certain voltages)
60Hz – 380V to 480V and 220/110V to 240/120V (de-rates may apply at certain voltages)
- ▶ 6 wire reconnectable:
50Hz – 380V to 440V and 220V to 240V (de-rates may apply at certain voltages)
60Hz – 380V to 480V and 220V to 240V (de-rates may apply at certain voltages)

Winding Configurations	Standard		Special (dedicated)			
	12 wire Reconnectable	6 wire Reconnectable	380V and 600V 60Hz	690V 50/60Hz	220-240V 1ph 50Hz	220-240V 1ph 60Hz
ECP3 to ECO38	Std	Option	Option	Option	Option	Option
ECO40 to ECO46	Std	Option	Option	Option	Option (to ECO40)	
ECO47	Std 4 wires		Option	Option		
Insulation materials	Class H	Class H	Class H	Class H	Class H	Class H
High efficiency	Std	Std	Std	Std	Std	Std
High motor starting	>300%	>300%	>300%	>300%	>300%	>300%
THD (Total Harmonic Distortion)	Typically <3.5% full load L-L	Typically <3.0% full load L-L	Typically <3.5% full load L-L	Typically <3.5% full load L-L	Typically <4.5% full load L-N	Typically <4.5% full load L-N
Interference suppression	VDE 0875 G/N/K, EN61000-6-3, EN61000-6-2, others available on request					

Winding Protection

There are various degrees of protection for the windings following the standard impregnation process, as can be seen here. The TOTAL+ butadienic black flexible coating is recommended for arduous applications.

Winding Protection:	STANDARD	STANDARD+	GREY	GREY+	TOTAL+
ECP3	Std	Option	Option	Option	Option
ECP28 and ECP32	-	Std	Option	Option	Option
NPE32, ECP34 to ECO47	-	-	Std	Option	Option

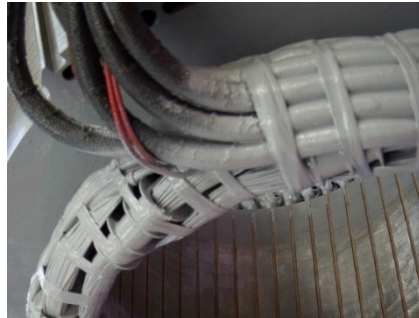

Grey treatment (marinization) on the left, TOTAL+ treatment shown on the right. The EG43 grey varnish, is an high temperature insulating enamel that forms a tough and flexible film, with excellent moisture and chemical protection. It is water and oil proof, and also protects windings from abrasion. It is applied spraying an over coating layer over the impregnated winding, or dipping the stator in a varnish barrel for superior treatments.

The TOTAL+ is a Mecc Alte protection system. It is the ultimate winding treatment that offers truly superior performances when the environment is really harsh, or the application very demanding. The TOTAL+ is also extremely resistant to the particle abrasion as it adsorbs the impacts.

Design

The robust mechanical structure withstands up to 5G in any direction and 9G vertically and its design permits easy access to the connections and components during routine maintenance check-ups. The mechanical design has used the most advanced FEM analysis. The materials used are: DD12 steel for the frame, C45 steel for the shaft and cast iron or aluminum pressure die cast for the end-brackets: fans are either aluminum die casted or nylon fiber glass loaded, UL compliant materials. Rotors are dynamically balanced according grades 6.3 (up to series 32) or 2.5 (from series 34 onwards) of ISO 1940-1.

Terminals and Terminal Box

Easy access to regulators is assured through a pull out drawer or a drop down panel to allow safer adjustment. Large terminal boxes allow easy access of power cables, in the ECO43 and ECO46 higher power ranges the terminal allow the convenient choice of power cable or busbar connection with versatility of entry and connection. Current transformers are available as an option on series ECO 40, 43, 46 and 47 with single or dual output.

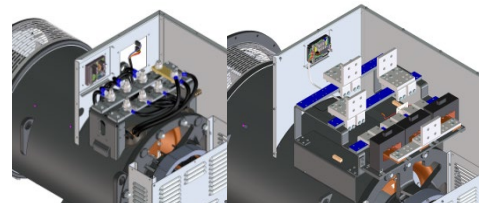

On C type family has been installed a new AVR panel. Terminal boards have been redesigned into a special L configuration, specifically to ease customer wiring; with this kind of terminal board it is possible to place a second terminal board in order to get 12 available terminals. Current transformers are available as an option on series ECO38 with single or dual output.

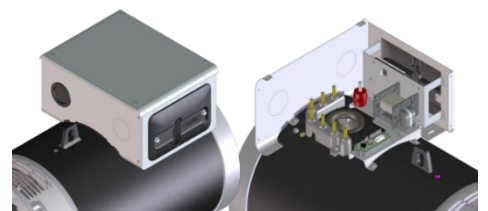

Ingress Protection

In addition to the protection on the windings themselves, alternators can increase the protection on the inlet side. Standard level is IP23 but the following solutions are also available: IP23 DP with inlet filters, IP23 with only terminal box in IP45, IP43 and IP45. Derates may be applied.

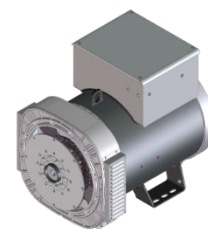

Info: https://www.meccalte.com/downloads/MA0605_Bulletin_IP.pdf

Excitation and Regulation Systems

All ECP/ECO series have MAUX auxiliary winding to power the digital regulator. Both DSR and the DER1 are available to connect to PC through the DxR2 USB interface and DxR TERMINAL software to interrogate/download alarms & settings for analysis or for cloning other regulators. DER2 has got an integrated USB connection and can be connected to the PC without any optional connection boards. More settings such as LAMS, digital RAM based synchronous external control and soft start are obtainable through the DxR connection. Simple analogue potentiometers are available for the more usual adjustments.

Excitation Systems	DSR	DER1	DER2
ECP3 to ECO38	Std	Option	Option
ECO40 to ECO46	-	Std	Option
ECO47	-	-	Std
Parallel Operation	√	√	√
Mains Parallel	√	√	√
3 Phase Sensing (rms)	-	√	√
Accuracy	+/-1%	+/-0.5%	+/-0.5%
Remote Voltage Control	√	√	√
Alarm Log	√	√	√
Analogue and Digital Configurable	√	√	√
LAMS (Load Acceptance V/f)	√	√	√
APO (Active Protection Output)	√	√	√
Soft Start	√	√	√
High dynamic response	-	-	√
USB connection without external boards	-	-	√

For a given motor start duty a smaller generator may be selected – as it has lower subtransient reactance values for non-linear loads. The whole range from 6.5 to 3400kVA is capable of >300% sustained short circuit current for up to 20 seconds.

Optional PMG

The Mecc Alte PMG is available on ECP28, ECP30, ECP32, ECP34 and ECO38 as factory-fitted option; alternatively, only the predisposition for the retrofit, for subsequent assembly, is available on option.

On ECO 40, 43 and 46 series it is available as a factory-fitted or retro-fitted options.

For ECO47 PMG is standard.

The complete AVR range is fully compatible with both MAUX and PMG systems, this minimises spare part management and flexibility of stock as one AVR suits all applications. The PMG is delivering the same amount of kVA available with the MAUX.

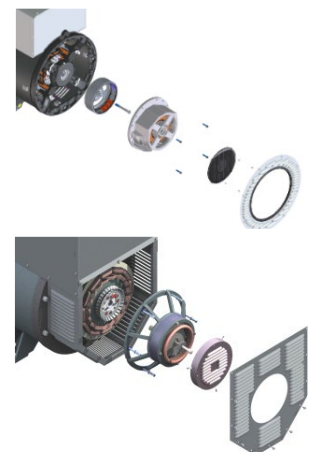

Dew Heater

Our entire range can be equipped with anti-condensation resistors of adequate power and sized for the alternator. Voltage for heaters must be specified when ordering. New cylindrical cartridge style heaters are available on request and it can be retrofitted.

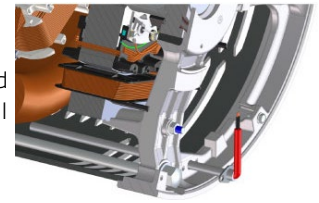

Accessories

Additional optionals can be fit on our alternator series, such as PTC thermistors or PT100 both on windings and bearings, dew heaters, high and low profile of terminal boxes (on most series), parallel devices, current and voltage transformers, air filters, IP43 and IP45 protections and many others.

For more info visit: <https://www.meccalte.com/en/products/alternators/accessories/c-type-accessories>

Deration coefficients

Altitude (meters)	Ambient temperature (Celsius)							
	25	40	45	50	55	60	65	70
≤ 1000	1.07	1	0.96	0.93	0.91	0.89	0.85	0.82
$> 1000 \leq 1500$	1.01	0.96	0.92	0.89	0.87	0.84	0.81	0.77
$> 1500 \leq 2000$	0.96	0.91	0.87	0.84	0.83	0.79	0.77	0.73
$> 2000 \leq 3000$	0.90	0.85	0.81	0.78	0.76	0.73	0.71	0.68
$> 3000 \leq 4000$	0.84	0.78	0.75	0.73	0.70	0.68	0.66	0.62
$> 4000 \leq 5000$	0.78	0.72	0.69	0.67	0.65	0.62	0.59	0.56
$> 5000 \leq 6000$	0.70	0.65	0.63	0.61	0.58	0.55	0.53	0.50

Notes on short circuit curves

The indicated coefficients have to be used to correct the three phase short circuit curves values as a function of the rated voltage.

The indicated coefficient have to be used to correct the three phase short circuit curves values as a function of the type of short circuit voltage.

50 Hz		60 Hz			3 phase	2 phase L-L	1 phase L-N
Voltage	Factor	Voltage	Factor				
380	0.93X	415	0.85X	<i>Istantaneous</i>	1X	0.87X	1.30X
400	1X	440	0.90X	<i>Minimum</i>	1X	1.80X	3.20X
415	1.04X	460	0.95X	<i>Sustained</i>	1X	1.50X	2.50X
440	1.10X	480	1X	<i>Max Duration</i>	20 sec.	10 sec.	4 sec.

All the curves are shown for series or parallel star connection at 400V 50 Hz or 480V 60 Hz. If the unit is reconnected from series to parallel star, the additional coefficient is 2X. From series star to series delta, it is 1.72X. From series star to parallel delta, it is 3.44X.

General characteristics

Pole number	2	Insulation class	H
Phase number	3	Protection class	IP23
Number of wires	12	NDE Bearing type	6311.2RS
Execution	Brushless	DE Bearing type	6314.2Z
Regulator type	DSR	Maximum Overspeed	4300
Winding pitch	2/3	Altitude	0-1000
Code voltage reference	T0405S3	Balancing	ISO1940-1

Ratings 50Hz

kVA / kW @ Temp. Rise / Ambient °C - 0.8 PF																					
STANDBY-163/27					STANDBY-150/40				H-125/40				F-105/40				B-80/40				
Series	380V	400V	415V	440V	380V	400V	415V	440V	380V	400V	415V	440V	380V	400V	415V	440V	380V	400V	415V	440V	
Parallel Star YY	190V	200V	208V	220V	190V	200V	208V	220V	190V	200V	208V	220V	190V	200V	208V	220V	190V	200V	208V	220V	
Series Delta Δ	220V	230V	240V	254V	220V	230V	240V	254V	220V	230V	240V	254V	220V	230V	240V	254V	220V	230V	240V	254V	
Parallel Delta ΔΔ	110V	115V	120V	127V	110V	115V	120V	127V	110V	115V	120V	127V	110V	115V	120V	127V	110V	115V	120V	127V	
ECP34 1S2 A	kVA	110	110	110	93,5	105	105	105	90	100	100	100	85	90	90	90	75	80	80	80	68
	kW	88	88	88	75	84,5	84,5	84,5	72	80	80	80	68	72	72	72	60	64	64	64	54,5
ECP34 2S2 A	kVA	135	135	135	118	130	130	130	114	125	125	125	110	113	113	113	100	100	100	100	88
	kW	108	108	108	95	104	104	104	91,5	100	100	100	88	90,5	90,5	90,5	80	80	80	80	70,5
ECP34 1L2 A	kVA	168	168	168	140	162	162	162	135	156	156	156	130	140	140	140	115	124	124	124	104
	kW	134	134	134	112	129	129	129	108	124	124	124	104	112	112	112	92	100	100	100	83
ECP34 2L2 A	kVA	184	184	184	162	177	177	177	156	170	170	170	150	154	154	154	135	136	136	136	120
	kW	147	147	147	129	141	141	141	124	136	136	136	120	123	123	123	108	108	108	108	96

Ratings 60Hz

kVA / kW @ Temp. Rise / Ambient °C - 0.8 PF																					
STANDBY-163/27					STANDBY-150/40				H-125/40				F-105/40				B-80/40				
Series	415V	440V	460V	480V	415V	440V	460V	480V	415V	440V	460V	480V	415V	440V	460V	480V	415V	440V	460V	480V	
Parallel Star YY	208V	220V	230V	240V	208V	220V	230V	240V	208V	220V	230V	240V	208V	220V	230V	240V	208V	220V	230V	240V	
Series Delta Δ	240V	254V	265V	277V	240V	254V	265V	277V	240V	254V	265V	277V	240V	254V	265V	277V	240V	254V	265V	277V	
Parallel Delta ΔΔ	120V	127V	133V	138V	120V	127V	133V	138V	120V	127V	133V	138V	120V	127V	133V	138V	120V	127V	133V	138V	
ECP34 1S2 A	kVA	115	132	132	132	111	127	127	127	105	120	120	120	95	108	108	108	84	96	96	96
	kW	92,5	105	105	105	89	101	101	101	84	96	96	96	76	86,5	86,5	86,5	67	77	77	77
ECP34 2S2 A	kVA	140	162	162	162	135	156	156	156	130	150	150	150	120	135	135	135	104	120	120	120
	kW	112	129	129	129	108	124	124	124	104	120	120	120	96	108	108	108	83	96	96	96
ECP34 1L2 A	kVA	172	187	202	202	166	181	195	195	160	174	187	187	145	156	169	169	128	139	149	149
	kW	138	150	161	161	133	145	156	156	128	139	149	149	116	124	135	135	102	111	119	119
ECP34 2L2 A	kVA	185	207	220	220	179	200	213	213	175	196	208	208	160	173	188	188	140	156	166	166
	kW	148	165	176	176	143	160	170	170	140	156	166	166	128	138	150	150	112	125	133	133

Reactance & Time constants- Class H / 400V

Unsaturated (ref. EN60034-4)			ECP34 1S2 A	ECP34 2S2 A	ECP34 1L2 A	ECP34 2L2 A
X_d	Direct-axis synchronous reactance	%	415,2	429,5	399,6	445,2
X'_d	Direct-axis transient reactance	%	18,3	17,6	15,8	15,7
X''_d	Direct-axis subtransient reactance	%	9,82	9,04	7,93	7,2
X_q	Quadrature-axis synchronous reactance	%	156,9	167,5	154,1	188,7
X'_q	Quadrature-axis transient reactance	%	156,9	167,5	154,1	188,7
X''_q	Quadrature-axis subtransient reactance	%	27	26,3	23,5	25,6
X₂	Negative-sequence reactance	%	17,8	17,1	19,4	15,8
X₀	Zero sequence reactance	%	3,79	3,57	3,09	3,1
Saturated						
X_d	Direct-axis synchronous reactance	%	352,9	365,1	339,7	378,4
X'_d	Direct-axis transient reactance	%	15,6	15	13,4	13,3
X''_d	Direct-axis subtransient reactance	%	8,35	7,68	6,74	6,12
X_q	Quadrature-axis synchronous reactance	%	133,4	142,4	131	160,4
X'_q	Quadrature-axis transient reactance	%	133,4	142,4	131	160,4
X''_q	Quadrature-axis subtransient reactance	%	23	22,4	20	21,8
X₂	Negative-sequence reactance	%	15,1	14,5	16,5	13,4
X₀	Zero sequence reactance	%	3,79	3,57	3,09	3,1
K_{cc}	Short circuit ratio		0,28	0,27	0,29	0,26
T'_d	Transient time constant	sec	0,038	0,038	0,035	0,053
T''_d	Subtransient time constant	sec	0,009	0,009	0,009	0,009
T'_{do}	Open circuit time constant	sec	1,2	1,4	1,3	1,1
T_a	Armature time constant	sec	0,02	0,021	0,02	0,019

Additional information - Class H / 400V

I_o	Excitation current at no load	A	0,4	0,3	0,4	0,5
I_c	Excitation current at full load	A	3,0	2,9	3,2	3,2
Overload						
Overload per 10 sec.			300			
Heat dissipation		W	8889	10254	12042	12148
Telephone Harmonic Factor - THF		%	<2	<2	<2	<2
Waveform Distors.(THD) full load LL/LN		%	2,2 / 3,6	1,2 / 4,5	3,6 / 4,8	1,7 / 4,7
Waveform Distors.(THD) no load LL/LN		%	3,2 / 4,7	2,7 / 4,2	3,1 / 4,9	2,1 / 4,9

Reactance & Time constants- Class H / 480V

Unsaturated (ref. EN60034-4)			ECP34 1S2 A	ECP34 2S2 A	ECP34 1L2 A	ECP34 2L2 A
X_d	Direct-axis synchronous reactance	%	415,2	429,5	399,2	453,9
X'_d	Direct-axis transient reactance	%	18,3	17,6	15,8	16
X''_d	Direct-axis subtransient reactance	%	9,82	9,04	7,92	7,34
X_q	Quadrature-axis synchronous reactance	%	156,9	167,5	153,9	192,4
X'_q	Quadrature-axis transient reactance	%	156,9	167,5	153,9	192,4
X''_q	Quadrature-axis subtransient reactance	%	27	26,3	23,5	26,1
X₂	Negative-sequence reactance	%	17,8	17,1	19,4	16,1
X₀	Zero sequence reactance	%	3,79	3,57	3,09	3,16
Saturated						
X_d	Direct-axis synchronous reactance	%	352,9	365,1	339,3	385,8
X'_d	Direct-axis transient reactance	%	15,6	15	13,4	13,6
X''_d	Direct-axis subtransient reactance	%	8,35	7,68	6,73	6,24
X_q	Quadrature-axis synchronous reactance	%	133,4	142,4	130,8	163,5
X'_q	Quadrature-axis transient reactance	%	133,4	142,4	130,8	163,5
X''_q	Quadrature-axis subtransient reactance	%	23	22,4	20	22,2
X₂	Negative-sequence reactance	%	15,1	14,5	16,5	13,7
X₀	Zero sequence reactance	%	3,79	3,57	3,09	3,16
K_{cc}	Short circuit ratio		0,28	0,27	0,29	0,26
T'_d	Transient time constant	sec	0,038	0,038	0,035	0,053
T''_d	Subtransient time constant	sec	0,009	0,009	0,009	0,009
T'_{do}	Open circuit time constant	sec	1,2	1,4	1,3	1,1
T_a	Armature time constant	sec	0,02	0,021	0,02	0,019

Additional information - Class H / 480V

I_o	Excitation current at no load	A	0,3	0,3	0,4	0,5
I_c	Excitation current at full load	A	2,8	3,0	3,1	3,1
Overload						
Overload per 10 sec.			300			
Heat dissipation			W			
			8575	10152	11607	11568
Telephone Interference Factor - TIF			<40			
Waveform Distors.(THD) full load LL/LN			%			
			2,2 / 3,6	1,2 / 4,5	3,6 / 4,8	1,7 / 4,7
Waveform Distors.(THD) no load LL/LN			%			
			3,2 / 4,7	2,7 / 4,2	3,1 / 4,9	2,1 / 4,9

Efficiencies @ 50Hz

Models		380V 50Hz					400V 50Hz					415V 50Hz					440V 50Hz				
		0.25	0.5	0.75	1	1.1	0.25	0.5	0.75	1	1.1	0.25	0.5	0.75	1	1.1	0.25	0.5	0.75	1	1.1
ECP34 1S2 A	%	85,2	88,9	90,1	89,9	89,6	85,0	89,0	90,4	90,0	89,7	84,8	89,0	90,3	89,7	89,4	84,8	88,8	90,0	89,5	89,2
ECP34 2S2 A	%	85,9	89,4	90,7	90,6	90,3	85,7	89,5	91,0	90,7	90,4	85,5	89,5	90,9	90,4	90,1	85,5	89,3	90,6	90,2	89,9
ECP34 1L2 A	%	86,4	89,9	91,4	91,1	90,8	86,2	90,0	91,7	91,2	90,9	86,0	90,0	91,6	90,9	90,6	86,0	89,8	91,3	90,7	90,4
ECP34 2L2 A	%	87,0	90,5	92,0	91,7	91,4	86,8	90,6	92,3	91,8	91,5	86,6	90,6	92,2	91,5	91,2	86,6	90,4	91,9	91,3	91,0

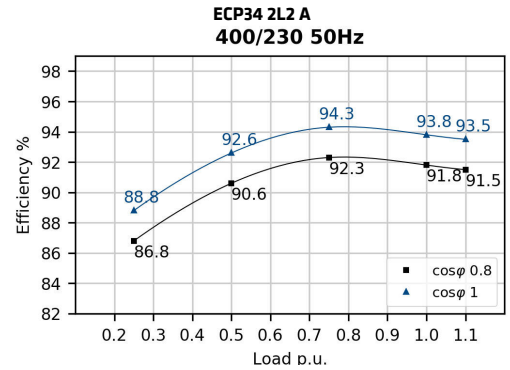
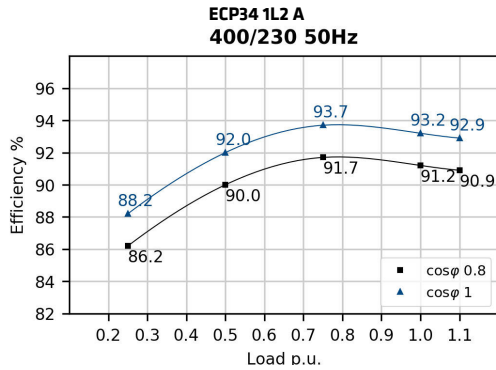
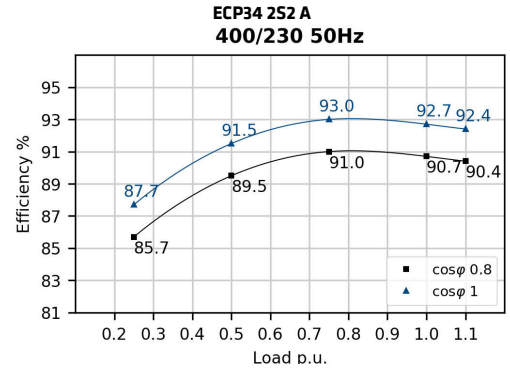
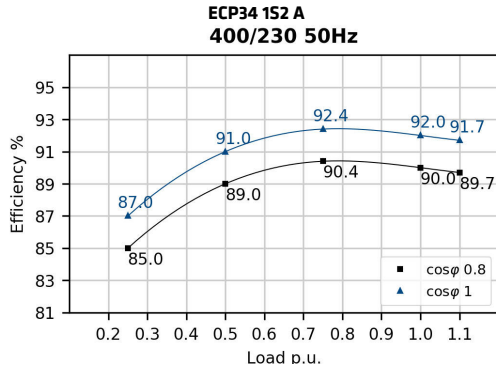

Efficiencies @ 60Hz

Models		415V 60Hz					440V 60Hz					460V 60Hz					480V 60Hz				
		0.25	0.5	0.75	1	1.1	0.25	0.5	0.75	1	1.1	0.25	0.5	0.75	1	1.1	0.25	0.5	0.75	1	1.1
ECP34 1S2 A	%	86,2	90,2	92,1	91,1	90,8	86,2	90,3	92,3	91,6	91,3	86,2	90,4	92,4	91,7	91,4	86,0	90,5	92,6	91,8	91,5
ECP34 2S2 A	%	86,4	90,7	92,4	91,5	91,2	86,4	90,8	92,6	92,0	91,7	86,4	90,9	92,7	92,1	91,8	86,2	91,0	92,9	92,2	91,9
ECP34 1L2 A	%	88,0	91,3	92,9	92,1	91,8	88,0	91,4	93,1	92,6	92,3	88,0	91,5	93,2	92,7	92,4	87,8	91,6	93,4	92,8	92,5
ECP34 2L2 A	%	87,7	91,9	93,3	92,8	92,5	87,7	92,0	93,5	93,3	93,0	87,7	92,1	93,6	93,4	93,1	87,5	92,2	93,8	93,5	93,2

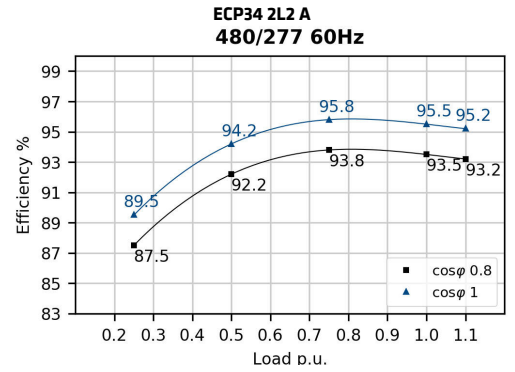
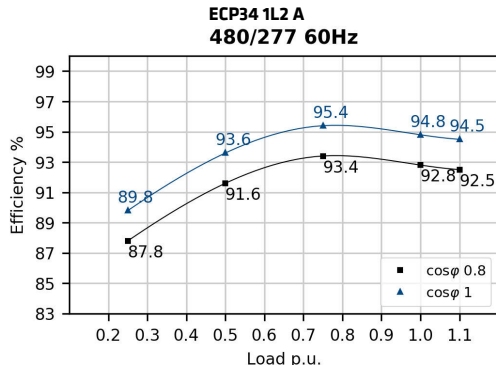
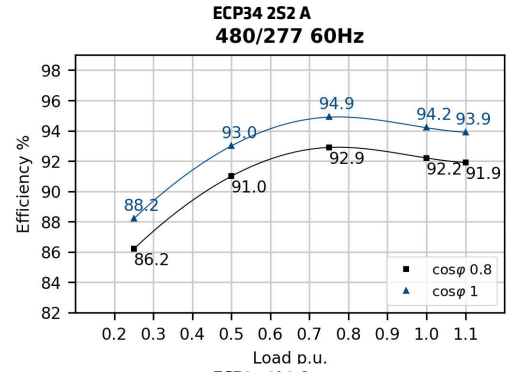
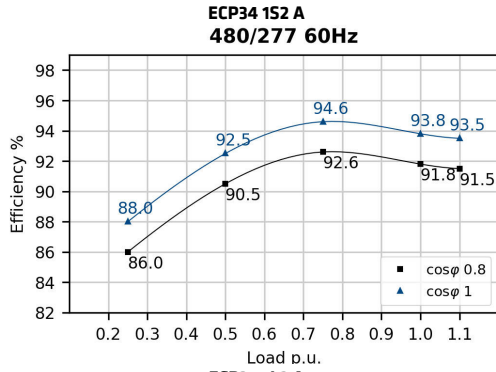

Transients voltage

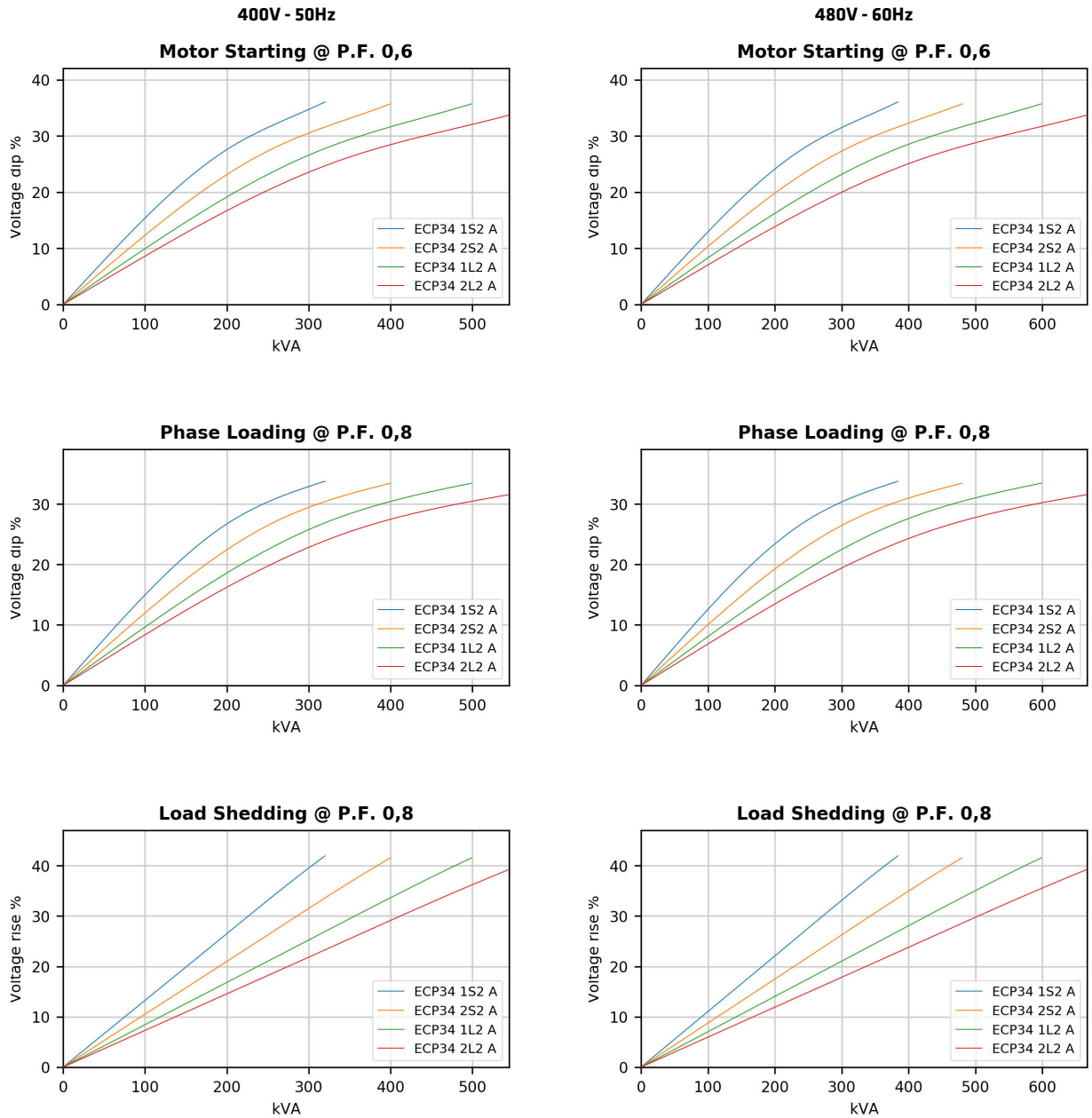

In order to scale transient curves as a function of a power factor or voltage if not indicated, please proceed as follows:

Power Factor coefficient corrector (PFCC), to be used on power factor 0.6 curves:

$$PFCC = \frac{\sin(\text{ARCCos}(PF_{\text{new}}))}{0.8}$$

Example. The PFCC at power factor 0.3 is 1.192 [$PFCC = \frac{\sin(\text{ARCCos}(0.3))}{0.8}$]. This means that the voltage fall at a given power at pf 0.3 is equivalent to the one that can be read on the pf 0.6 curve if the load is considered 1.192 times bigger (19% higher value.).

In this example, a 100 kVA load insertion at pf 0.3 is equivalent in voltage fall to a 119kVA load insertion at pf 0.6.

Voltage coefficient corrector (VCC):

$$VCC = \left(\frac{400}{V_{\text{new}}}\right)^2 \text{ if } 50 \text{ Hz}; VCC = \left(\frac{480}{V_{\text{new}}}\right)^2 \text{ if } 60 \text{ Hz}$$

Example. VCC at 415V 60 Hz is 1.338 [$VCC = \left(\frac{480}{415}\right)^2$]. This means that the voltage fall at a given power at 415V is equivalent to the one that can be read on the power factor 0.6 curve if the load is considered 1.338 times bigger (33% higher value.).

In this example, a 100 kVA load insertion at 415V is equivalent in voltage fall to a 133kVA load insertion at 480V.

50Hz Short circuit decrement curves - No load excitation at rated speed

ECP34 1S2 A

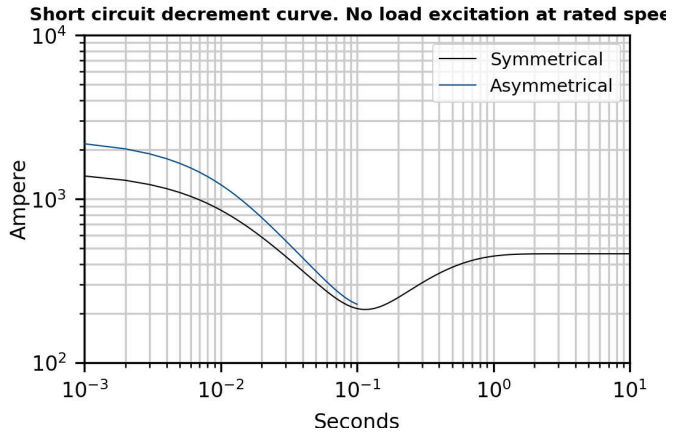

ECP34 2S2 A

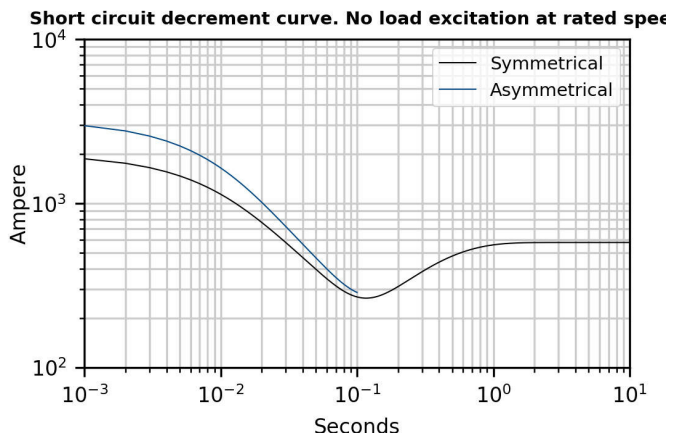

ECP34 1L2 A

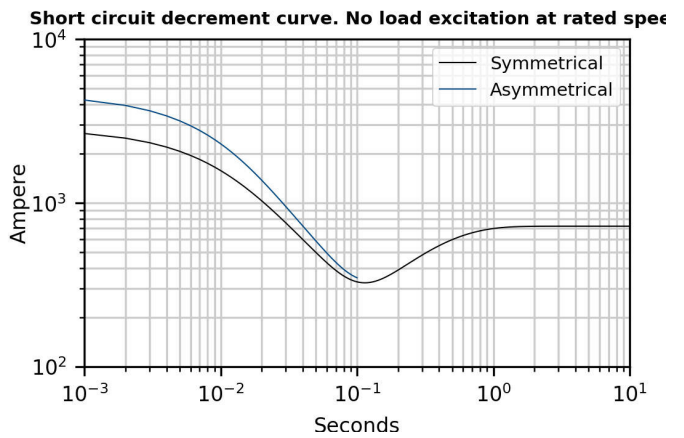

ECP34 2L2 A

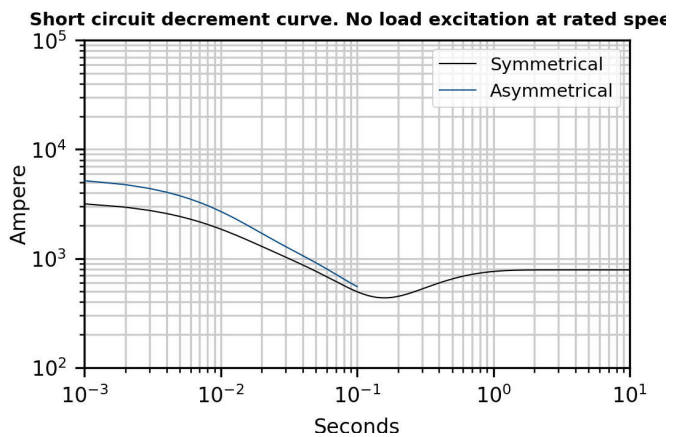

*Please refer to tables at page 6

60Hz Short circuit decrement curves - No load excitation at rated speed

ECP34 1S2 A

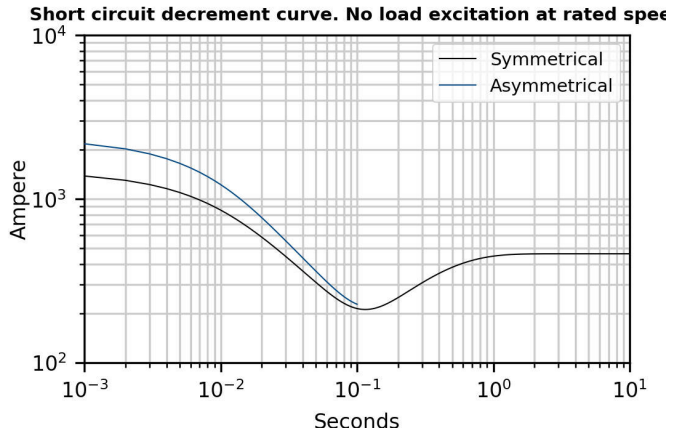

ECP34 2S2 A

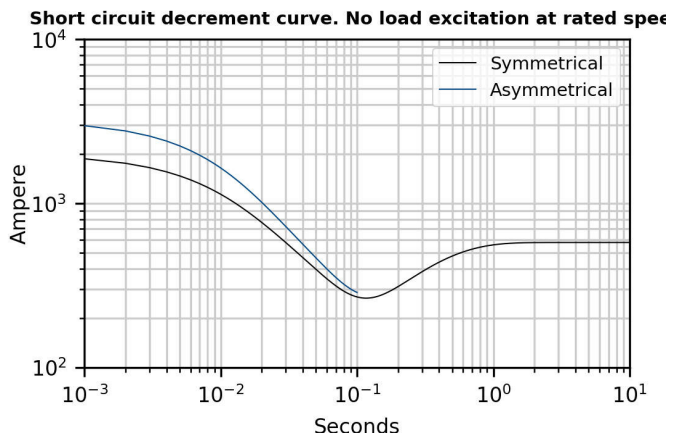

ECP34 1L2 A

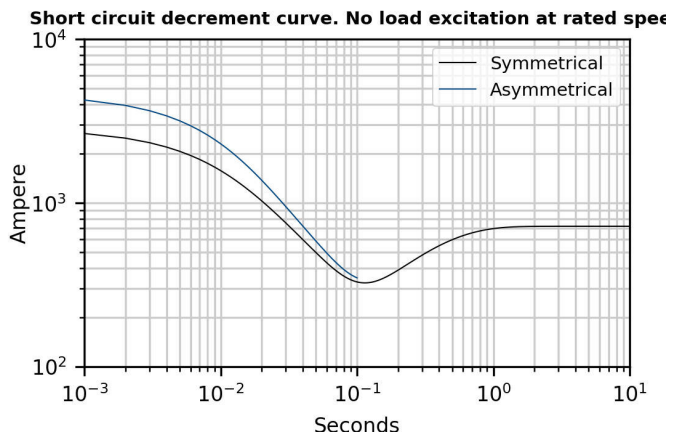

ECP34 2L2 A

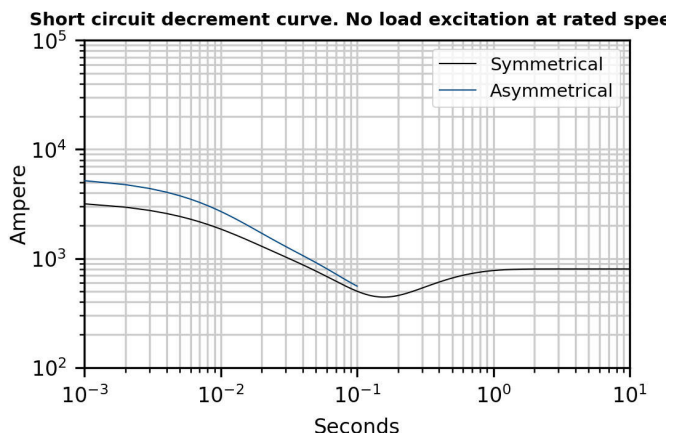

*Please refer to tables at page 6

Additional Characteristics

Data	ECP34 1S2 A		ECP34 2S2 A		ECP34 1L2 A		ECP34 2L2 A		
	50Hz	60Hz	50Hz	60Hz	50Hz	60Hz	50Hz	60Hz	
Damper cage	Aluminium								
Stator Winding Resistance (20°C)	Ω	0,095		0,111		0,013		0,009	
Rotor Winding Resistance (20°C)	Ω	1,45		1,63		1,906		2,003	
Stator Exciter Resistance (20°C)	Ω	15,28		15,28		15,28		15,28	
Rotor Exciter Resistance (20°C)	Ω	0,41		0,41		0,41		0,41	
Weight of complete generator	kg	344,0		413,0		456,0		492,0	
Unbalanced magnetic pull	kN/mm	3,9		4,1		4,4		4,5	
Air flow	m ³ /min	35,4	42,0	35,4	42,0	35,4	42,0	35,4	42,0
Noise level at 1m/7m	dB(A)	92/79	96/82	92/79	96/82	92/79	96/82	92/79	96/82

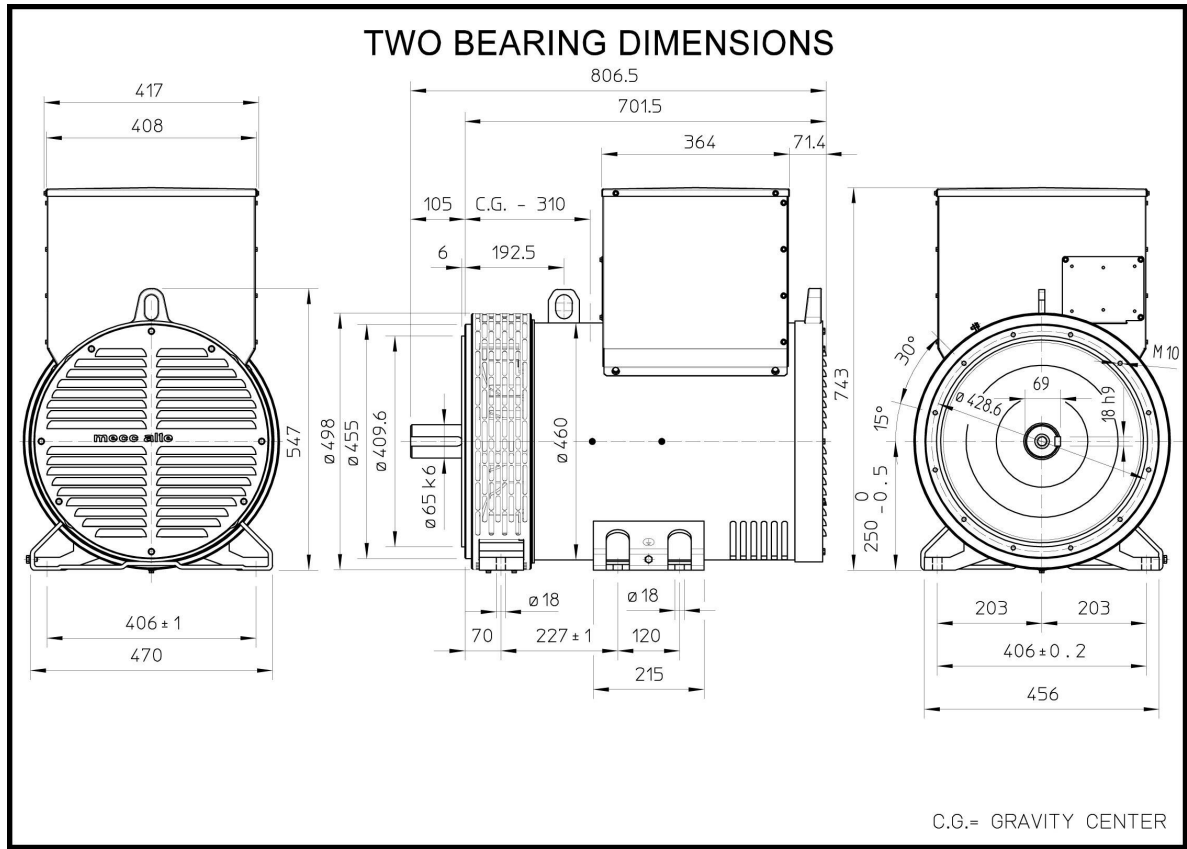

ECP34 1S2 A

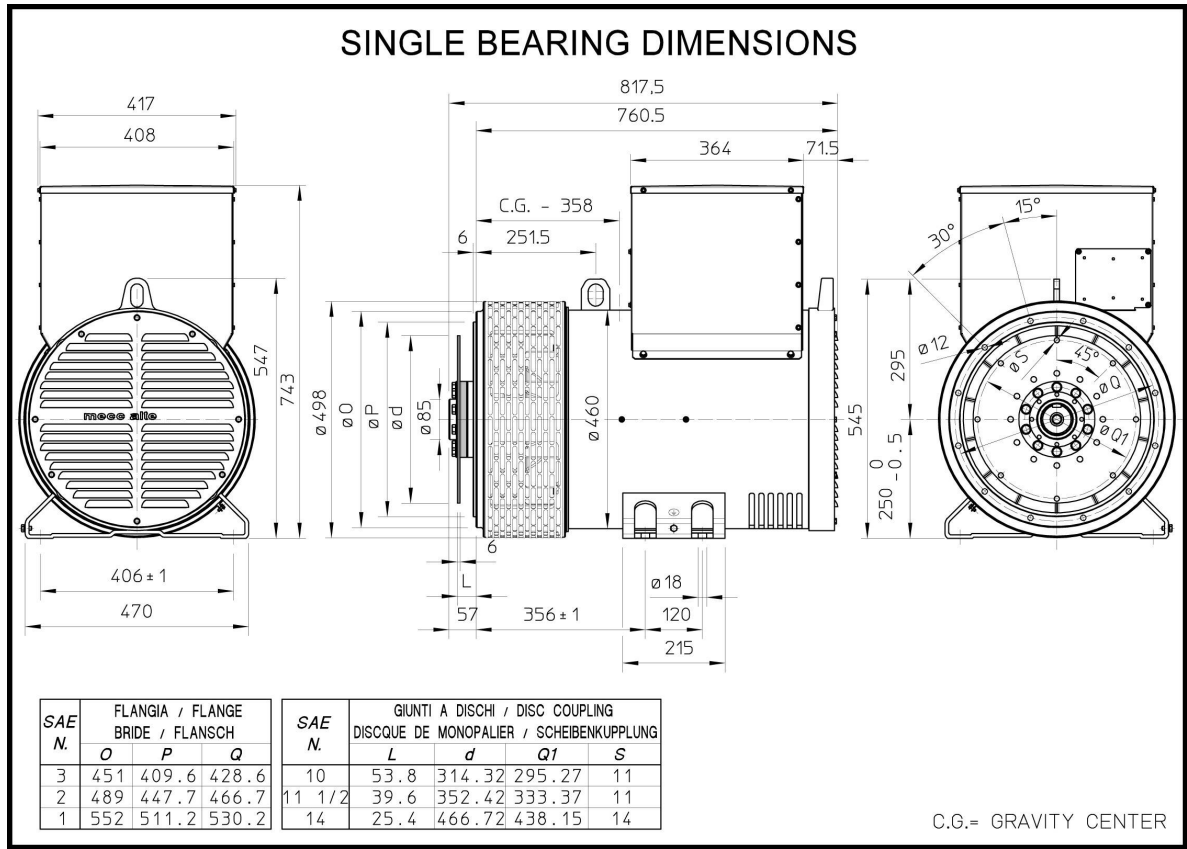

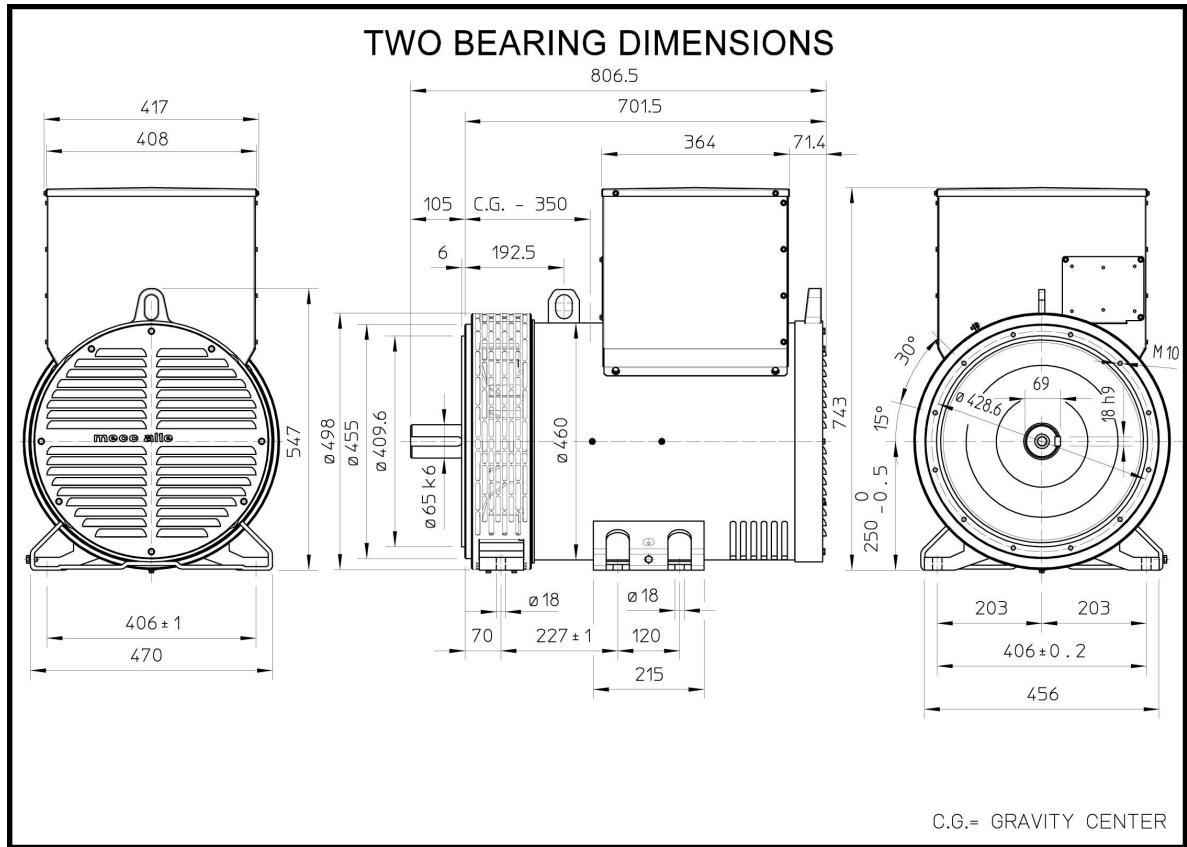

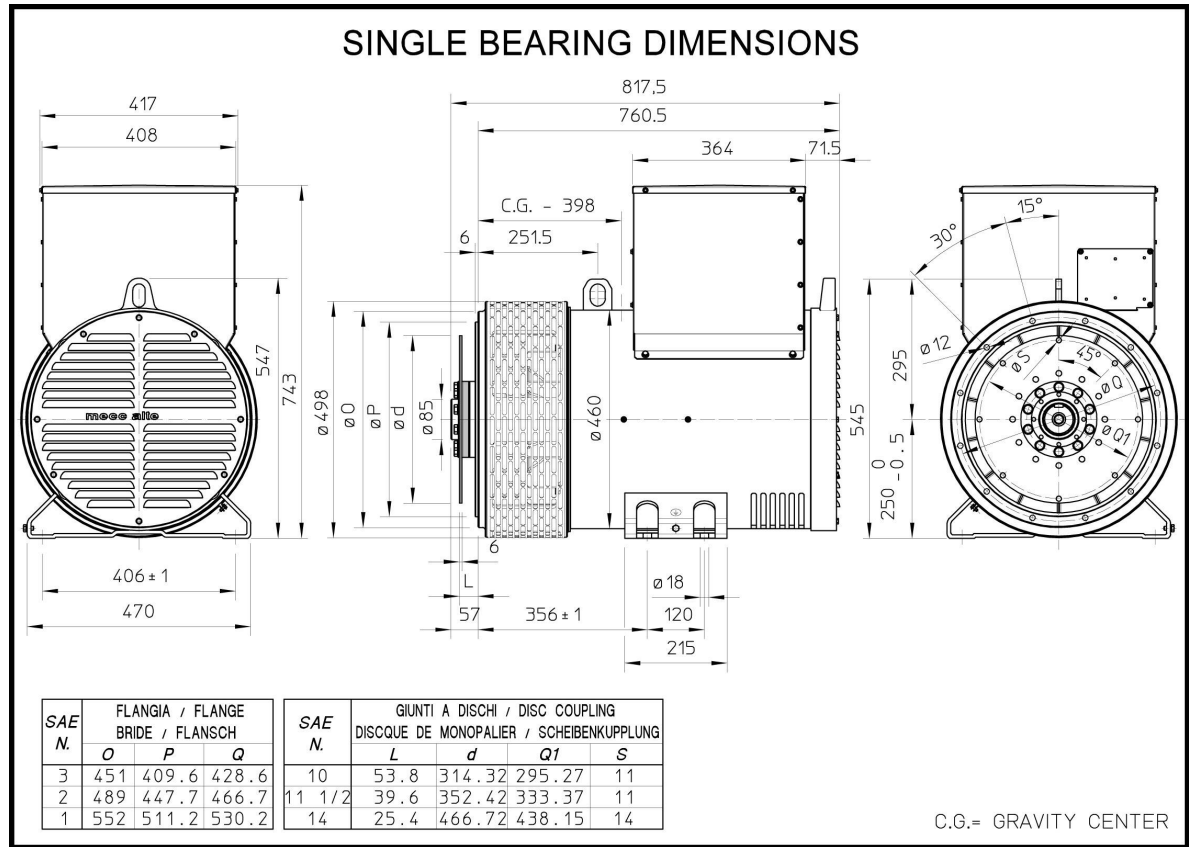

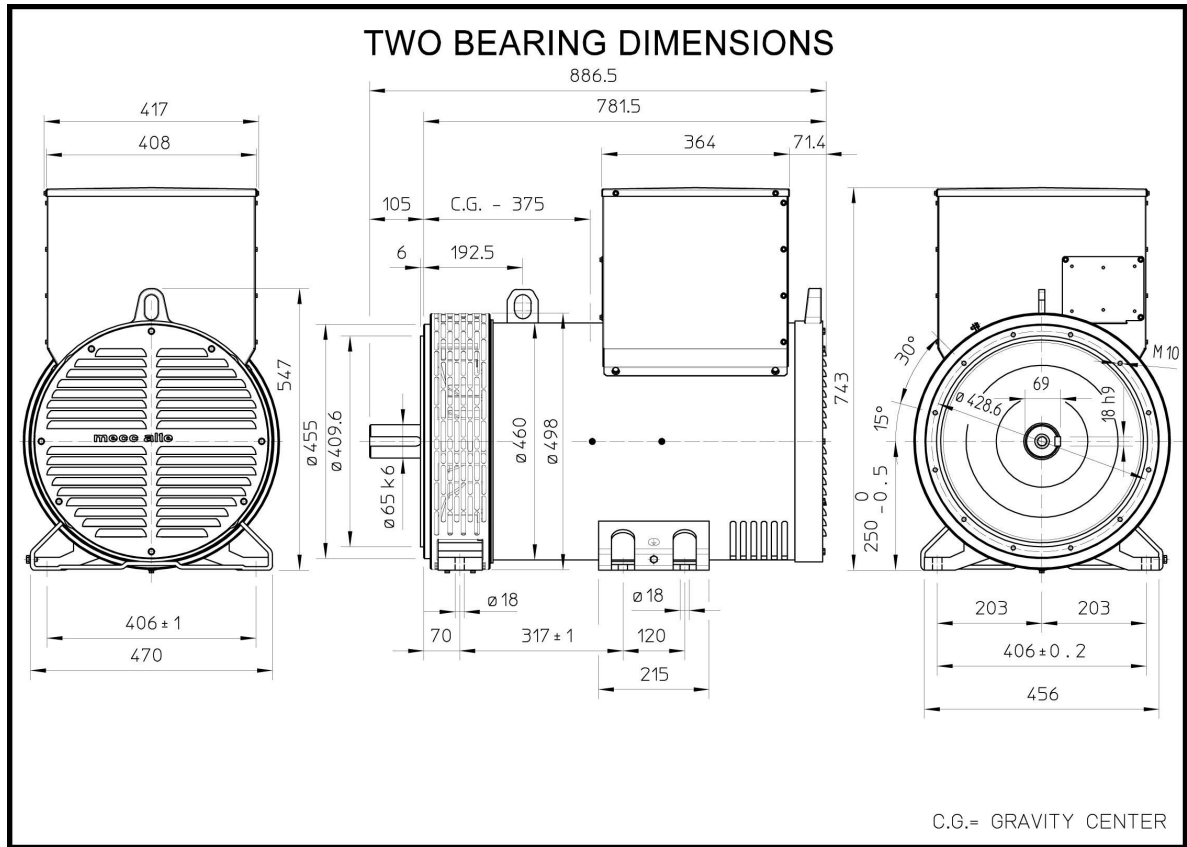

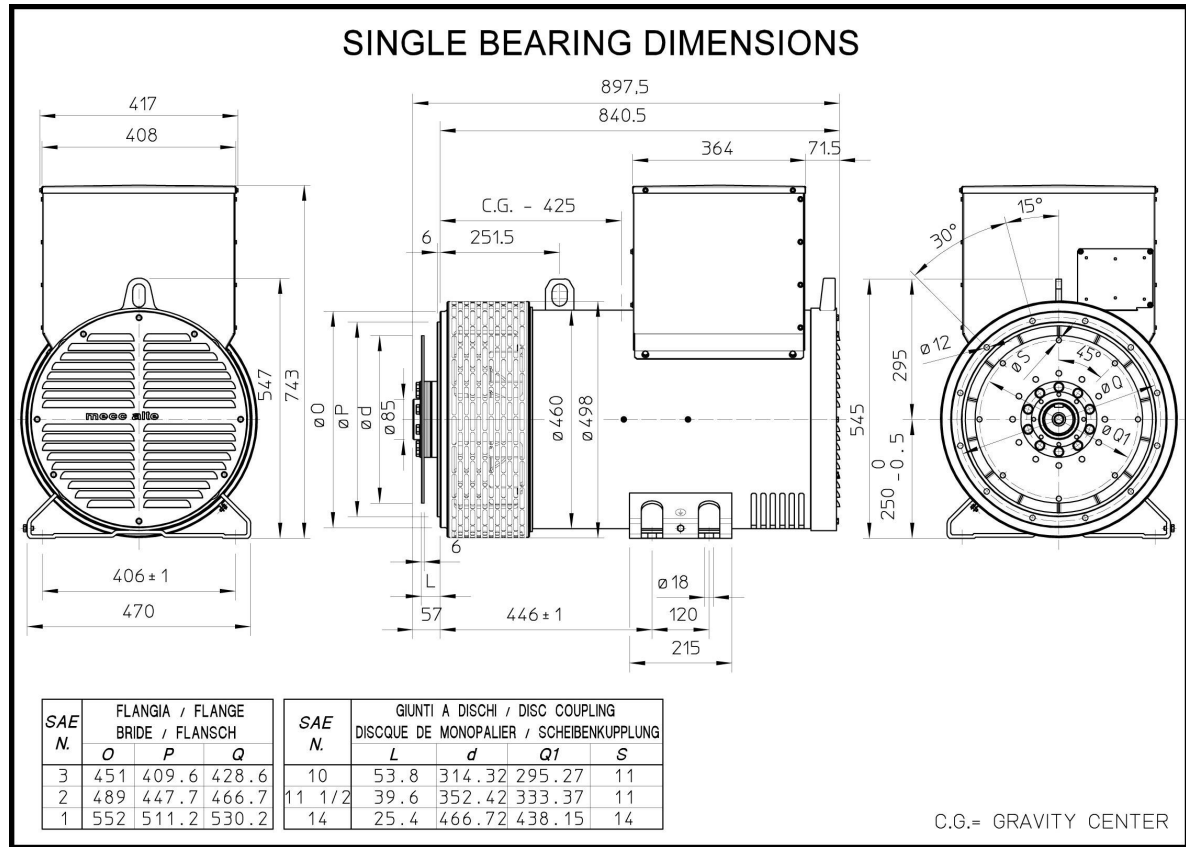

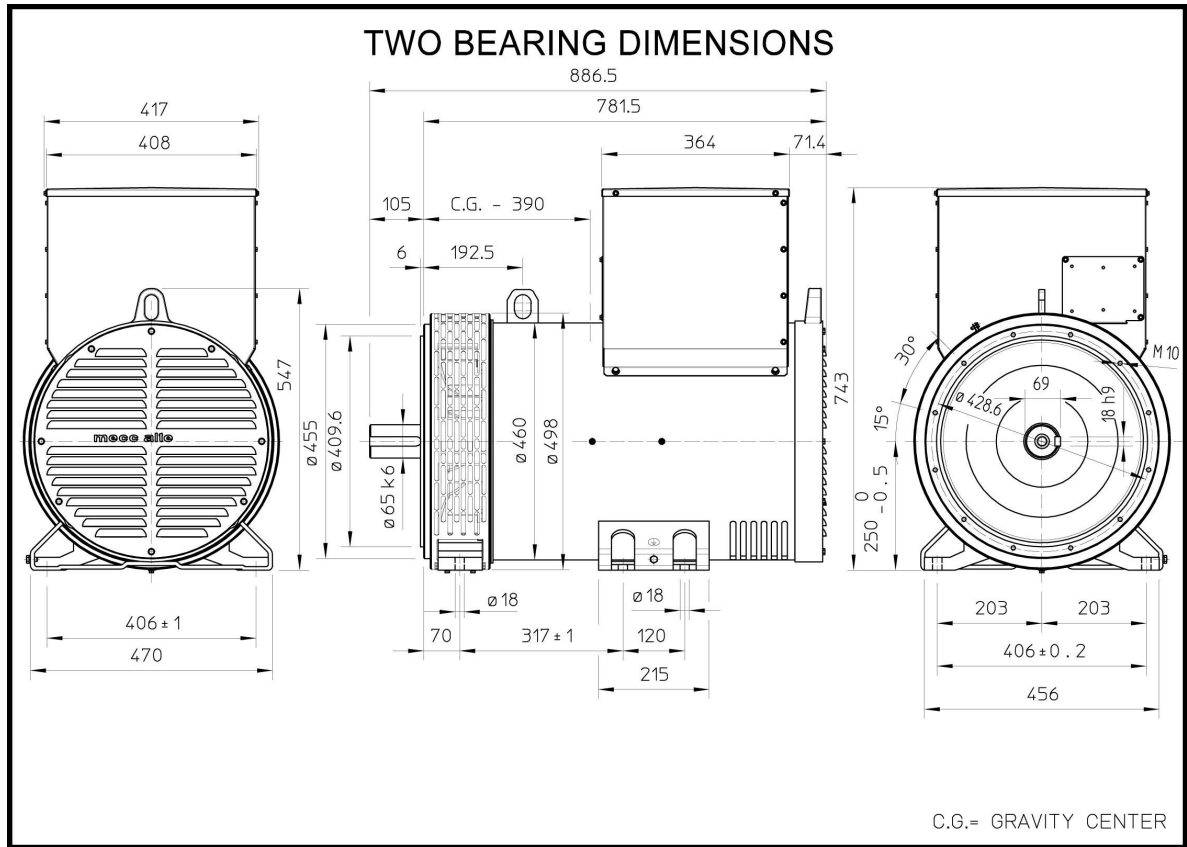

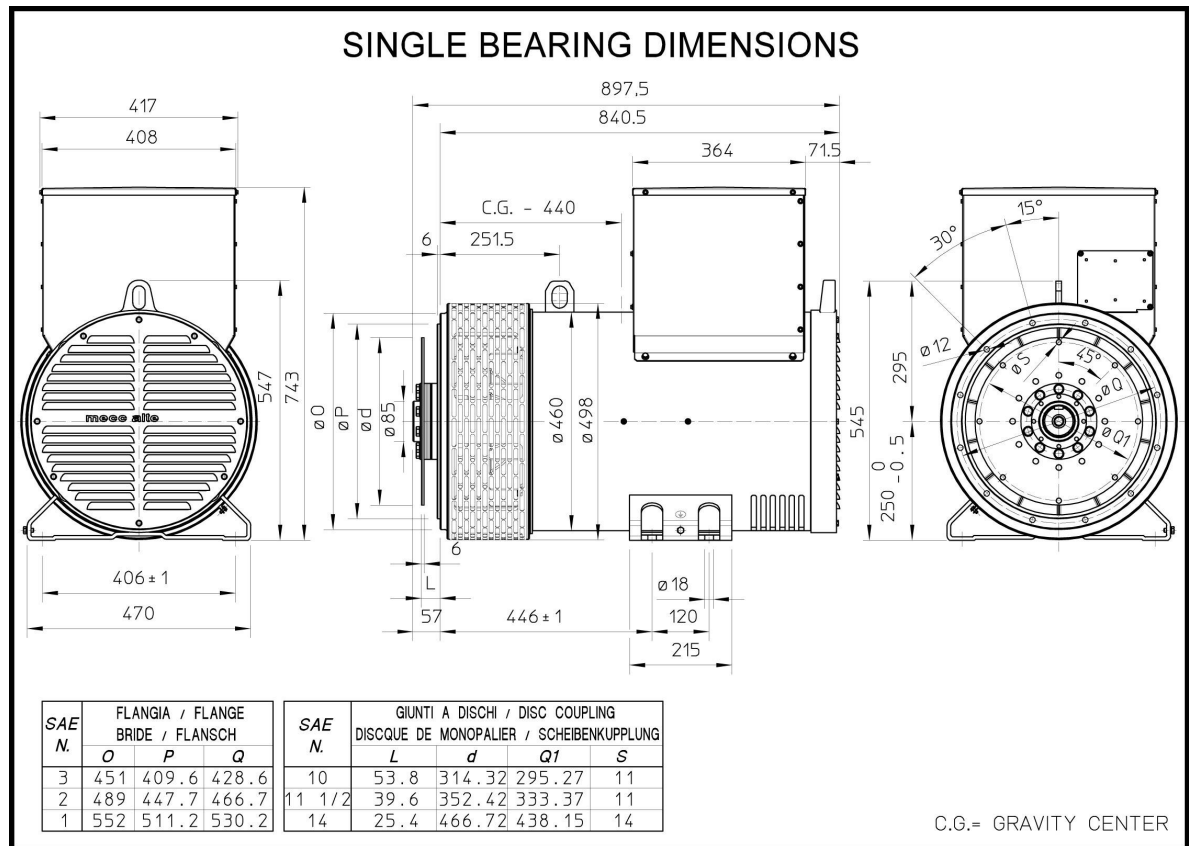

Mecc Alte SpA (HQ)

Via Roma
20 - 36051 Creazzo
Vicenza - ITALY
T: +39 0444 396111
E: info@meccalte.it
aftersales@meccalte.it

Mecc Alte Portable

Via Roma
20 - 36051 Creazzo
Vicenza - ITALY
T: +39 0444 396111
E: info@meccalte.it

Mecc Alte Power Products srl

Via Melaro
2 - 36075 Montecchio
Maggiore (VI) - ITALY
T: +39 0444 1831295
E: info@meccalte.it

Zanardi Alternatori srl

Via Dei Laghi
48/B - 36077 Altavilla
Vicenza - ITALY
T: +39 0444 370799
E: info@zanardialternatori.it

United Kingdom

Mecc Alte U.K. LTD
6 Lands' End Way
Oakham
Rutland LE15 6RF
T: +44 (0) 1572 771160
E: info@meccalte.co.uk

Spain

Mecc Alte España S.A.
C/ Rio Taibilla, 2
Polig. Ind. Los Valeros
03178 Benijofar (Alicante)
T: +34 (0) 96 6702152
E: info@meccalte.es

China

Mecc Alte Alternator Haimen LTD
755 Nanghai East Rd
Jiangsu HEDZ 226100 PRC
T: +86 (0) 513 82325758
E: info@meccalte.cn

India

Mecc Alte India PVT LTD
Plot NO: 1, Sanaswadi
Talegaon
Dhamdhare Road Taluka:
Shirur, District:
Pune - 412208
Maharashtra, India
T: +91 2137 619600
E: info@meccalte.in

U.S.A. and Canada

Mecc Alte Inc.
1229 Adams Drive
McHenry, IL, 60051
T: +1 815 344 0530
E: info@meccalte.us

Germany

Mecc Alte Generatoren GmbH
Bucher Hang 2
D-87448 Waltenhofen
T: +49 (0)831 540755 0
E: info@meccalte.de

Australia

Mecc Alte Alternators PTY LTD
10 Duncan Road, PO Box 1046
Dry Creek, 5094, South
Australia
T: +61 (0) 8 8349 8422
E: info@meccalte.com.au

France

Mecc Alte International S.A.
Z.E.La Gagnerie
16330 ST.Amant de Boixe
T: +33 (0) 545 397562
E: info@meccalte.fr

Far East

Mecc Alte (F.E.) PTE LTD
19 Kian Teck Drive
Singapore 628836
T: +65 62 657122
E: info@meccalte.com.sg



www.meccalte.com