



Totally Focused. Totally Independent.

Technical Specification

EC040 4 C



The world's largest
independent producer of
alternators 1 – 5,000kVA

Standards

Alternators are designed and produced within an ISO 9001 environment. The entire series is manufactured according to, and complies with, the most common specifications such as CEI 2-3, IEC 34-1, EN 60034-1, VDE 0530, BS 4999-5000, NF 51.111, NEMA MG 1-2011, ISO 8528-3. They also comply with other specific standards such as UL1446, UL 1004/4 and /B and CAN/CSA-C22.2 No14-95-No100-95.

Windings and Performances

All windings are 2/3rds pitch to eliminate triplen harmonics within the voltage waveform and to avoid excessive neutral currents in certain parallel operating conditions. A fully interconnected aluminium or copper damper cage is supplied on the rotor of all models (excluding the ECP3 series).

- ▶ 12 wire reconnectable:
50Hz – 380V to 440V and 220/110V to 240/120V (de-rates may apply at certain voltages)
60Hz – 380V to 480V and 220/110V to 240/120V (de-rates may apply at certain voltages)
- ▶ 6 wire reconnectable:
50Hz – 380V to 440V and 220V to 240V (de-rates may apply at certain voltages)
60Hz – 380V to 480V and 220V to 240V (de-rates may apply at certain voltages)

Winding Configurations	Standard		Special (dedicated)			
	12 wire Reconnectable	6 wire Reconnectable	380V and 600V 60Hz	690V 50/60Hz	220-240V 1ph 50Hz	220-240V 1ph 60Hz
ECP3 to ECO38	Std	Option	Option	Option	Option	Option
ECO40 to ECO46	Std	Option	Option	Option	Option (to ECO40)	
ECO47	Std 4 wires		Option	Option		
Insulation materials	Class H	Class H	Class H	Class H	Class H	Class H
High efficiency	Std	Std	Std	Std	Std	Std
High motor starting	>300%	>300%	>300%	>300%	>300%	>300%
THD (Total Harmonic Distortion)	Typically <3.5% full load L-L	Typically <3.0% full load L-L	Typically <3.5% full load L-L	Typically <3.5% full load L-L	Typically <4.5% full load L-N	Typically <4.5% full load L-N
Interference suppression	VDE 0875 G/N/K, EN61000-6-3, EN61000-6-2, others available on request					

Winding Protection

There are various degrees of protection for the windings following the standard impregnation process, as can be seen here. The TOTAL+ butadienic black flexible coating is recommended for arduous applications.

Winding Protection:	STANDARD	STANDARD+	GREY	GREY+	TOTAL+
ECP3	Std	Option	Option	Option	Option
ECP28 and ECP32	-	Std	Option	Option	Option
NPE32, ECP34 to ECO47	-	-	Std	Option	Option

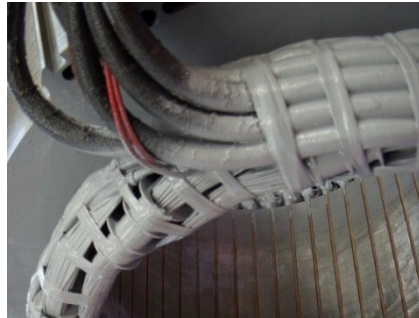

Grey treatment (marinization) on the left, TOTAL+ treatment shown on the right. The EG43 grey varnish, is an high temperature insulating enamel that forms a tough and flexible film, with excellent moisture and chemical protection. It is water and oil proof, and also protects windings from abrasion. It is applied spraying an over coating layer over the impregnated winding, or dipping the stator in a varnish barrel for superior treatments.

The TOTAL+ is a Mecc Alte protection system. It is the ultimate winding treatment that offers truly superior performances when the environment is really harsh, or the application very demanding. The TOTAL+ is also extremely resistant to the particle abrasion as it adsorbs the impacts.

Design

The robust mechanical structure withstands up to 5G in any direction and 9G vertically and its design permits easy access to the connections and components during routine maintenance check-ups. The mechanical design has used the most advanced FEM analysis. The materials used are: DD12 steel for the frame, C45 steel for the shaft and cast iron or aluminum pressure die cast for the end-brackets: fans are either aluminum die casted or nylon fiber glass loaded, UL compliant materials. Rotors are dynamically balanced according grades 6.3 (up to series 32) or 2.5 (from series 34 onwards) of ISO 1940-1.

Terminals and Terminal Box

Easy access to regulators is assured through a pull out drawer or a drop down panel to allow safer adjustment. Large terminal boxes allow easy access of power cables, in the ECO43 and ECO46 higher power ranges the terminal allow the convenient choice of power cable or busbar connection with versatility of entry and connection. Current transformers are available as an option on series ECO 40, 43, 46 and 47 with single or dual output.

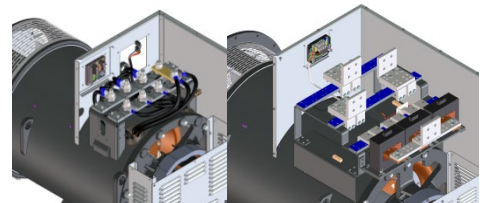

On C type family has been installed a new AVR panel. Terminal boards have been redesigned into a special L configuration, specifically to ease customer wiring; with this kind of terminal board it is possible to place a second terminal board in order to get 12 available terminals. Current transformers are available as an option on series ECO38 with single or dual output.

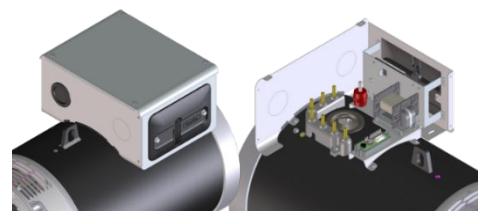

Ingress Protection

In addition to the protection on the windings themselves, alternators can increase the protection on the inlet side. Standard level is IP23 but the following solutions are also available: IP23 DP with inlet filters, IP23 with only terminal box in IP45, IP43 and IP45. Derates may be applied.

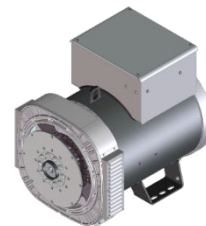

Info: https://www.meccalte.com/downloads/MA0605_Bulletin_IP.pdf

Excitation and Regulation Systems

All ECP/ECO series have MAUX auxiliary winding to power the digital regulator. Both DSR and the DER1 are available to connect to PC through the DxR2 USB interface and DxR TERMINAL software to interrogate/download alarms & settings for analysis or for cloning other regulators. DER2 has got an integrated USB connection and can be connected to the PC without any optional connection boards. More settings such as LAMS, digital RAM based synchronous external control and soft start are obtainable through the DxR connection. Simple analogue potentiometers are available for the more usual adjustments.

Excitation Systems	DSR	DER1	DER2
ECP3 to ECO38	Std	Option	Option
ECO40 to ECO46	-	Std	Option
ECO47	-	-	Std
Parallel Operation	√	√	√
Mains Parallel	√	√	√
3 Phase Sensing (rms)	-	√	√
Accuracy	+/-1%	+/-0.5%	+/-0.5%
Remote Voltage Control	√	√	√
Alarm Log	√	√	√
Analogue and Digital Configurable	√	√	√
LAMS (Load Acceptance V/f)	√	√	√
APO (Active Protection Output)	√	√	√
Soft Start	√	√	√
High dynamic response	-	-	√
USB connection without external boards	-	-	√

For a given motor start duty a smaller generator may be selected – as it has lower subtransient reactance values for non-linear loads. The whole range from 6.5 to 3400kVA is capable of >300% sustained short circuit current for up to 20 seconds.

Optional PMG

The Mecc Alte PMG is available on ECP28, ECP30, ECP32, ECP34 and ECO38 as factory-fitted option; alternatively, only the predisposition for the retrofit, for subsequent assembly, is available on option.

On ECO 40, 43 and 46 series it is available as a factory-fitted or retro-fitted options.

For ECO47 PMG is standard.

The complete AVR range is fully compatible with both MAUX and PMG systems, this minimises spare part management and flexibility of stock as one AVR suits all applications. The PMG is delivering the same amount of kVA available with the MAUX.

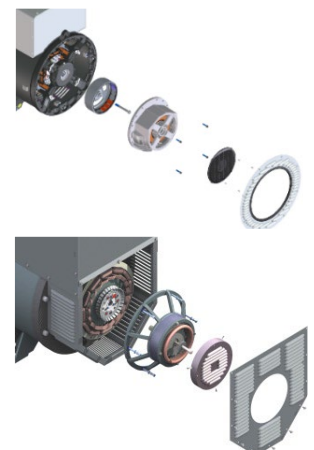

Dew Heater

Our entire range can be equipped with anti-condensation resistors of adequate power and sized for the alternator. Voltage for heaters must be specified when ordering. New cylindrical cartridge style heaters are available on request and it can be retrofitted.

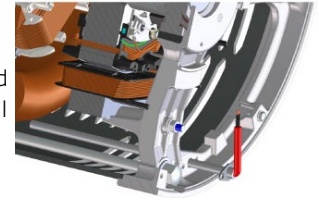

Accessories

Additional optionals can be fit on our alternator series, such as PTC thermistors or PT100 both on windings and bearings, dew heaters, high and low profile of terminal boxes (on most series), parallel devices, current and voltage transformers, air filters, IP43 and IP45 protections and many others.

For more info visit: <https://www.meccalte.com/en/products/alternators/accessories/c-type-accessories>

Deration coefficients

Altitude (meters)	Ambient temperature (Celsius)							
	25	40	45	50	55	60	65	70
≤ 1000	1.07	1	0.96	0.93	0.91	0.89	0.85	0.82
$> 1000 \leq 1500$	1.01	0.96	0.92	0.89	0.87	0.84	0.81	0.77
$> 1500 \leq 2000$	0.96	0.91	0.87	0.84	0.83	0.79	0.77	0.73
$> 2000 \leq 3000$	0.90	0.85	0.81	0.78	0.76	0.73	0.71	0.68
$> 3000 \leq 4000$	0.84	0.78	0.75	0.73	0.70	0.68	0.66	0.62
$> 4000 \leq 5000$	0.78	0.72	0.69	0.67	0.65	0.62	0.59	0.56
$> 5000 \leq 6000$	0.70	0.65	0.63	0.61	0.58	0.55	0.53	0.50

Notes on short circuit curves

The indicated coefficients have to be used to correct the three phase short circuit curves values as a function of the rated voltage.

The indicated coefficient have to be used to correct the three phase short circuit curves values as a function of the type of short circuit voltage.

50 Hz		60 Hz			3 phase	2 phase L-L	1 phase L-N
Voltage	Factor	Voltage	Factor				
380	0.93X	415	0.85X	<i>Istantaneous</i>	1X	0.87X	1.30X
400	1X	440	0.90X	<i>Minimum</i>	1X	1.80X	3.20X
415	1.04X	460	0.95X	<i>Sustained</i>	1X	1.50X	2.50X
440	1.10X	480	1X	<i>Max Duration</i>	20 sec.	10 sec.	4 sec.

All the curves are shown for series or parallel star connection at 400V 50 Hz or 480V 60 Hz. If the unit is reconnected from series to parallel star, the additional coefficient is 2X. From series star to series delta, it is 1.72X. From series star to parallel delta, it is 3.44X.

General characteristics

Pole number	4	Insulation class	H
Phase number	3	Protection class	IP23
Number of wires	12	NDE Bearing type	6318.2RS
Execution	Brushless	DE Bearing type	6322
Regulator type	DER-1/A	Maximum Overspeed	2250
Winding pitch	2/3	Altitude	0-1000
Code voltage reference	T0405P3	Balancing	ISO1940-1

Ratings 50Hz

kVA / kW @ Temp. Rise / Ambient °C - 0.8 PF		STANDBY-163/27				STANDBY-150/40				H-125/40				F-105/40				B-80/40			
Series	Star Y	760V	800V	830V	880V	760V	800V	830V	880V	760V	800V	830V	880V	760V	800V	830V	880V	760V	800V	830V	880V
	Parallel Star YY	380V	400V	415V	440V	380V	400V	415V	440V	380V	400V	415V	440V	380V	400V	415V	440V	380V	400V	415V	440V
	Series Delta Δ	440V	460V	480V	508V	440V	460V	480V	508V	440V	460V	480V	508V	440V	460V	480V	508V	440V	460V	480V	508V
	Parallel Delta ΔΔ	220V	230V	240V	254V	220V	230V	240V	254V	220V	230V	240V	254V	220V	230V	240V	254V	220V	230V	240V	254V
ECO40 1S4 C	kVA	440	440	440	404	417	417	417	386	400	400	400	370	370	370	370	342	320	320	320	296
	kW	352	352	352	323	334	334	334	309	320	320	320	296	296	296	296	273	256	256	256	237
ECO40 2S4 C	kVA	491	491	491	393	468	468	468	375	450	450	450	360	410	410	410	330	360	360	360	288
	kW	393	393	393	314	374	374	374	300	360	360	360	288	328	328	328	264	288	288	288	230
ECO40 3S4 C	kVA	550	550	550	503	521	521	521	479	500	500	500	460	450	450	450	414	400	400	400	368
	kW	440	440	440	402	417	417	417	383	400	400	400	368	360	360	360	331	320	320	320	294
ECO40 1L4 C	kVA	601	601	590	546	567	567	557	515	550	550	540	500	500	500	490	454	440	440	432	400
	kW	481	481	472	437	454	454	446	412	440	440	432	400	400	400	392	363	352	352	346	320
ECO40 2L4 C	kVA	675	675	675	616	645	645	645	588	625	625	625	570	564	564	564	515	500	500	500	456
	kW	540	540	540	493	516	516	516	470	500	500	500	456	451	451	451	412	400	400	400	365
ECO40 3L4 C	kVA	735	735	735	560	700	700	700	535	680	680	680	520	630	630	630	483	544	544	544	416
	kW	588	588	588	448	560	580	580	428	544	544	544	416	504	504	504	386	435	435	435	333
ECO40 VL4 C	kVA	825	825	825	740	777	777	777	700	750	750	750	680	690	690	690	630	600	600	600	544
	kW	660	660	660	592	622	622	622	560	600	600	600	544	552	552	552	504	480	480	480	435

Ratings 60Hz

kVA / kW @ Temp. Rise / Ambient °C - 0.8 PF		STANDBY-163/27				STANDBY-150/40				H-125/40				F-105/40				B-80/40			
Series	Star Y	830V	880V	920V	960V	830V	880V	920V	960V	830V	880V	920V	960V	830V	880V	920V	960V	830V	880V	920V	960V
	Parallel Star YY	415V	440V	460V	480V	415V	440V	460V	480V	415V	440V	460V	480V	415V	440V	460V	480V	415V	440V	460V	480V
	Series Delta Δ	480V	504V	530V	554V	480V	504V	530V	554V	480V	504V	530V	554V	480V	504V	530V	554V	480V	504V	530V	554V
	Parallel Delta ΔΔ	240V	254V	265V	277V	240V	254V	265V	277V	240V	254V	265V	277V	240V	254V	265V	277V	240V	254V	265V	277V
ECO40 1S4 C	kVA	459	492	525	525	438	469	500	500	420	450	480	480	383	410	440	440	336	360	384	384
	kW	367	394	420	420	350	375	400	400	336	360	384	384	306	328	352	352	269	288	307	307
ECO40 2S4 C	kVA	524	557	590	590	500	532	563	563	480	510	540	540	435	460	490	490	384	408	432	432
	kW	419	446	472	472	400	426	450	450	384	408	432	432	348	368	392	392	307	326	346	346
ECO40 3S4 C	kVA	590	634	660	660	563	604	625	625	540	580	600	600	484	520	540	540	432	464	480	480
	kW	472	507	528	528	450	483	500	500	432	464	480	480	387	416	432	432	346	371	384	384
ECO40 1L4 C	kVA	623	669	722	722	587	649	680	680	570	630	660	660	515	570	600	600	456	504	528	528
	kW	498	535	578	578	470	519	544	544	456	504	528	528	412	456	480	480	365	403	422	422
ECO40 2L4 C	kVA	720	762	810	810	688	730	775	775	665	705	750	750	605	636	677	677	532	564	600	600
	kW	576	610	648	648	550	584	620	620	532	564	600	600	484	509	542	542	426	451	480	480
ECO40 3L4 C	kVA	778	843	882	882	741	803	840	840	720	780	816	816	665	720	756	756	576	624	653	653
	kW	622	674	706	706	593	642	672	672	576	624	653	653	532	576	604	604	461	499	522	522
ECO40 VL4 C	kVA	930	970	970	970	885	925	925	925	860	900	900	900	790	830	830	830	688	720	720	720
	kW	744	776	776	776	708	740	740	740	688	720	720	720	632	664	664	664	550	576	576	576

Reactance & Time constants- Class H / 400V

Unsaturated (ref. EN60034-4)			ECO40 1S4 C	ECO40 2S4 C	ECO40 3S4 C	ECO40 1L4 C	ECO40 2L4 C	ECO40 3L4 C	ECO40 VL4 C
X_d	Direct-axis synchronous reactance	%	286,7	240,1	258,7	246,3	270	234,9	175,9
X'_d	Direct-axis transient reactance	%	23,3	22,1	21,7	20,1	19,8	18,7	16,7
X''_d	Direct-axis subtransient reactance	%	14,7	12,5	11,8	10,6	10,5	9,52	9
X_q	Quadrature-axis synchronous reactance	%	115,9	110,7	111,8	115,9	157,1	145,9	122,1
X'_q	Quadrature-axis transient reactance	%	115,9	110,7	111,8	115,9	157,1	145,9	122,1
X''_q	Quadrature-axis subtransient reactance	%	29,2	28,4	27,3	24,9	24	16,8	14,8
X₂	Negative-sequence reactance	%	19,1	18,2	17,3	13	12,4	14,6	12,5
X₀	Zero sequence reactance	%	3,62	3,21	3,1	2,9	2,9	2,48	2,28
Saturated									
X_d	Direct-axis synchronous reactance	%	238	199,3	214,7	204,4	224,1	195	146
X'_d	Direct-axis transient reactance	%	19,3	18,4	18	16,7	16,4	15,5	13,8
X''_d	Direct-axis subtransient reactance	%	12,2	10,4	9,79	8,76	8,72	7,9	7,47
X_q	Quadrature-axis synchronous reactance	%	96,2	91,9	92,8	96,2	130,4	121,1	101,4
X'_q	Quadrature-axis transient reactance	%	96,2	91,9	92,8	96,2	130,4	121,1	101,4
X''_q	Quadrature-axis subtransient reactance	%	24,2	23,5	22,7	20,7	19,9	13,9	12,3
X₂	Negative-sequence reactance	%	15,8	15,1	14,4	10,8	10,3	12,1	10,4
X₀	Zero sequence reactance	%	3,62	3,21	3,1	2,9	2,9	2,48	2,28
K_{cc}	Short circuit ratio		0,36	0,5	0,4	0,49	0,45	0,44	0,59
T'_d	Transient time constant	sec	0,16	0,13	0,14	0,14	0,15	0,18	0,18
T''_d	Subtransient time constant	sec	0,019	0,019	0,021	0,021	0,019	0,019	0,015
T'_{do}	Open circuit time constant	sec	2,55	2,7	2,8	2,9	3,1	3,1	3,7
T_a	Armature time constant	sec	0,017	0,03	0,031	0,04	0,04	0,052	0,071

Additional information - Class H / 400V

I_o	Excitation current at no load	A	0,9	0,9	0,5	0,8	0,9	0,7	0,7
I_c	Excitation current at full load	A	4,1	3,7	3,4	3,7	4,3	4,2	4,3
Overload									
Overload per 20 sec.						300			
Heat dissipation		W	19703	21356	22833	24135	26316	28632	30915
Telephone Harmonic Factor - THF		%	<2	<2	<2	<2	<2	<2	<2
Waveform Distors.(THD) full load LL/LN		%	2,6 / 2,6	2,7 / 2,8	2,4 / 2,5	2,5 / 2,5	2,2 / 2,4	2,1 / 2,1	2,2 / 2,2
Waveform Distors.(THD) no load LL/LN		%	2,9 / 2,9	2,5 / 2,6	2,6 / 2,5	2,3 / 2,4	2,4 / 2,5	2,4 / 2,4	2,5 / 2,5

Reactance & Time constants- Class H / 480V

Unsaturated (ref. EN60034-4)			ECO40 1S4 C	ECO40 2S4 C	ECO40 3S4 C	ECO40 1L4 C	ECO40 2L4 C	ECO40 3L4 C	ECO40 VL4 C
X_d	Direct-axis synchronous reactance	%	286,7	240,1	258,7	246,3	270	234,9	175,9
X'_d	Direct-axis transient reactance	%	23,3	22,1	21,7	20,1	19,8	18,7	16,7
X''_d	Direct-axis subtransient reactance	%	14,7	12,5	11,8	10,6	10,5	9,52	9
X_q	Quadrature-axis synchronous reactance	%	115,9	110,7	111,8	115,9	157,1	145,9	122,1
X'_q	Quadrature-axis transient reactance	%	115,9	110,7	111,8	115,9	157,1	145,9	122,1
X''_q	Quadrature-axis subtransient reactance	%	29,2	28,4	27,3	24,9	24	16,8	14,8
X₂	Negative-sequence reactance	%	19,1	18,2	17,3	13	12,4	14,6	12,5
X₀	Zero sequence reactance	%	3,62	3,21	3,1	2,9	2,9	2,48	2,28
Saturated									
X_d	Direct-axis synchronous reactance	%	238	199,3	214,7	204,4	224,1	195	146
X'_d	Direct-axis transient reactance	%	19,3	18,4	18	16,7	16,4	15,5	13,9
X''_d	Direct-axis subtransient reactance	%	12,2	10,4	9,79	8,76	8,72	7,9	7,47
X_q	Quadrature-axis synchronous reactance	%	96,2	91,9	92,8	96,2	130,4	121,1	101,3
X'_q	Quadrature-axis transient reactance	%	96,2	91,9	92,8	96,2	130,4	121,1	101,3
X''_q	Quadrature-axis subtransient reactance	%	24,2	23,5	22,7	20,7	19,9	13,9	12,3
X₂	Negative-sequence reactance	%	15,8	15,1	14,4	10,8	10,3	12,1	10,4
X₀	Zero sequence reactance	%	3,62	3,21	3,1	2,9	2,9	2,48	2,28
K_{cc}	Short circuit ratio		0,36	0,5	0,4	0,49	0,45	0,44	0,59
T'_d	Transient time constant	sec	0,16	0,13	0,14	0,14	0,15	0,18	0,18
T''_d	Subtransient time constant	sec	0,019	0,019	0,021	0,021	0,019	0,019	0,015
T'_{do}	Open circuit time constant	sec	2,55	2,7	2,8	2,9	3,1	3,1	3,7
T_a	Armature time constant	sec	0,017	0,03	0,031	0,04	0,04	0,052	0,071

Additional information - Class H / 480V

I_o	Excitation current at no load	A	0,9	0,9	0,5	0,8	0,9	0,7	0,7
I_c	Excitation current at full load	A	4,1	3,7	3,4	3,7	4,3	4,2	4,3
Overload									
Overload per 20 sec.						300			
Heat dissipation		W	19361	21305	22092	23148	23701	24386	25342
Telephone Interference Factor - TIF			<40	<40	<40	<40	<40	<40	<40
Waveform Distors.(THD) full load LL/LN		%	2,6 / 2,6	2,7 / 2,8	2,4 / 2,5	2,5 / 2,5	2,2 / 2,4	2,1 / 2,1	2,2 / 2,2
Waveform Distors.(THD) no load LL/LN		%	2,9 / 2,9	2,5 / 2,6	2,6 / 2,5	2,3 / 2,4	2,4 / 2,5	2,4 / 2,4	2,5 / 2,5

Efficiencies @ 50Hz

Models		380V 50Hz					400V 50Hz					415V 50Hz					440V 50Hz				
		0.25	0.5	0.75	1	1.1	0.25	0.5	0.75	1	1.1	0.25	0.5	0.75	1	1.1	0.25	0.5	0.75	1	1.1
ECO40 1S4 C	%	89,1	93,3	94,2	94,1	93,9	89,3	93,5	94,4	94,2	93,9	89,2	93,3	94,1	94,0	93,7	89,0	93,1	93,9	93,8	93,5
ECO40 2S4 C	%	89,4	93,5	94,3	94,1	93,9	89,5	93,8	94,6	94,4	94,2	89,4	93,7	94,5	94,2	93,9	89,2	93,5	94,1	93,9	93,7
ECO40 3S4 C	%	90,2	93,7	94,6	94,4	94,3	90,3	93,9	94,8	94,6	94,4	90,1	93,7	94,7	94,5	94,3	89,8	93,4	94,4	94,2	94,0
ECO40 1L4 C	%	90,5	94,0	94,9	94,7	94,5	90,5	94,1	95,0	94,8	94,5	90,3	94,0	94,9	94,6	94,2	90,0	93,8	94,5	94,4	94,2
ECO40 2L4 C	%	91,0	94,1	94,9	94,8	94,6	91,1	94,2	95,1	95,0	94,8	91,1	94,1	94,9	94,7	94,4	90,5	94,0	94,6	94,4	94,2
ECO40 3L4 C	%	91,4	94,1	95,0	94,8	94,6	91,5	94,3	95,2	95,0	94,8	91,3	94,2	95,0	94,7	94,4	90,8	93,8	94,4	94,5	94,4
ECO40 VL4 C	%	91,5	94,2	95,1	94,8	94,5	91,6	94,4	95,3	95,1	94,8	91,4	94,2	95,1	94,9	94,6	90,8	93,7	94,6	94,4	94,2

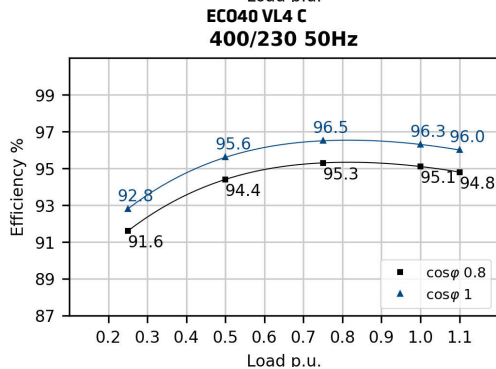
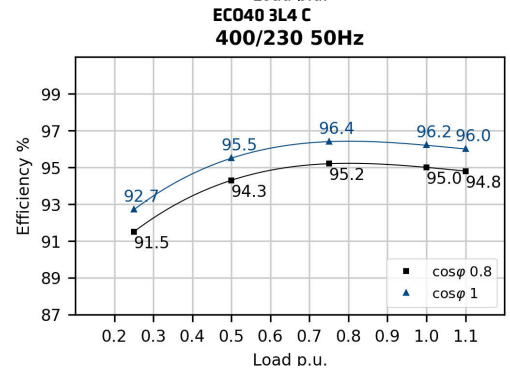
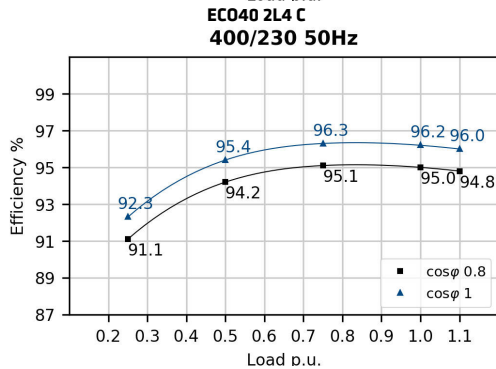
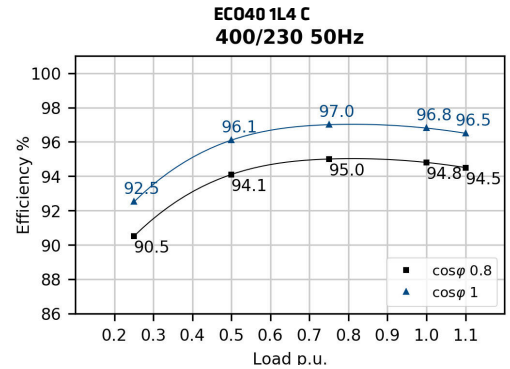
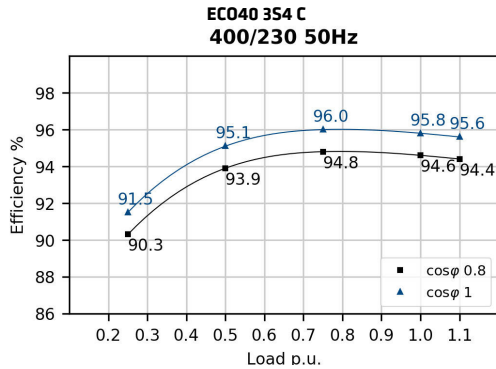
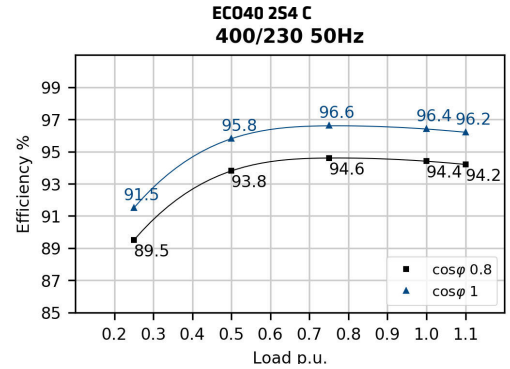
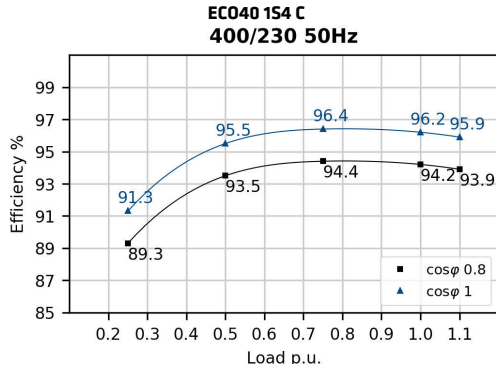

Efficiencies @ 60Hz

Models	415V 60Hz					440V 60Hz					460V 60Hz					480V 60Hz				
	0.25	0.5	0.75	1	1.1	0.25	0.5	0.75	1	1.1	0.25	0.5	0.75	1	1.1	0.25	0.5	0.75	1	1.1
ECO40 1S4 C	90,4	93,3	94,5	94,4	94,2	90,6	93,8	94,9	94,8	94,7	90,8	94,0	95,2	95,1	94,9	91,0	94,2	95,3	95,2	95,0
ECO40 2S4 C	90,6	93,5	94,6	94,5	94,3	90,9	94,0	95,1	95,0	94,8	91,1	94,2	95,3	95,2	94,9	91,2	94,4	95,5	95,3	95,0
ECO40 3S4 C	90,5	93,9	95,2	95,0	94,7	90,7	94,5	95,5	95,3	95,1	90,9	94,7	95,7	95,5	95,3	91,1	94,9	95,8	95,6	95,3
ECO40 1L4 C	91,0	94,7	95,5	95,3	95,1	91,1	94,8	95,7	95,6	95,5	91,1	94,9	95,8	95,7	95,6	91,3	95,1	96,0	95,8	95,6
ECO40 2L4 C	92,1	94,8	95,6	95,5	95,1	92,1	94,9	96,0	95,9	95,6	92,2	95,0	96,1	96,0	95,7	92,3	95,2	96,3	96,2	95,9
ECO40 3L4 C	91,4	94,8	95,8	95,7	95,3	91,5	95,0	96,1	96,0	95,7	91,7	95,2	96,4	96,2	95,9	92,1	95,5	96,6	96,4	96,0
ECO40 VL4 C	91,4	94,8	95,9	95,8	95,4	91,7	95,1	96,3	96,1	95,8	92,0	95,4	96,7	96,5	96,2	92,2	95,6	96,8	96,6	96,1

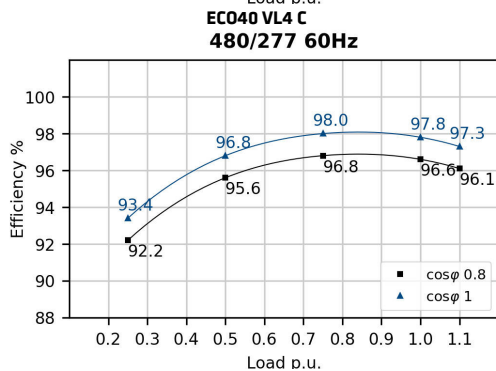
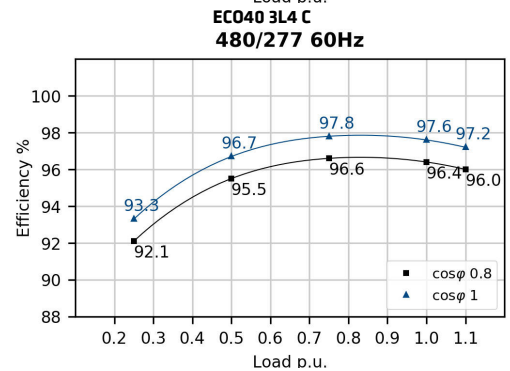
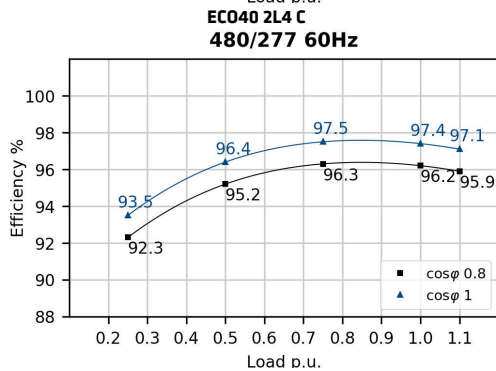
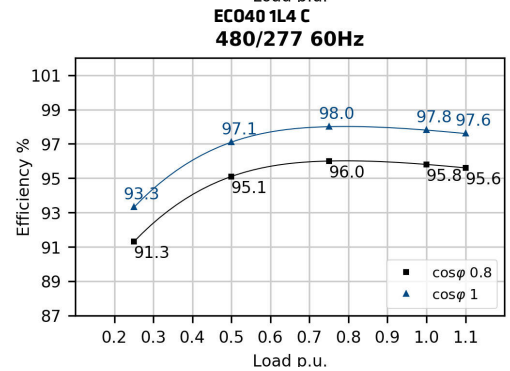
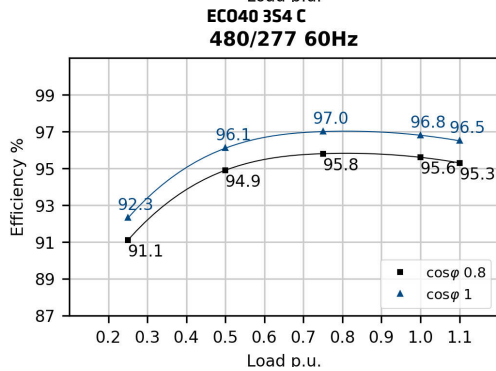
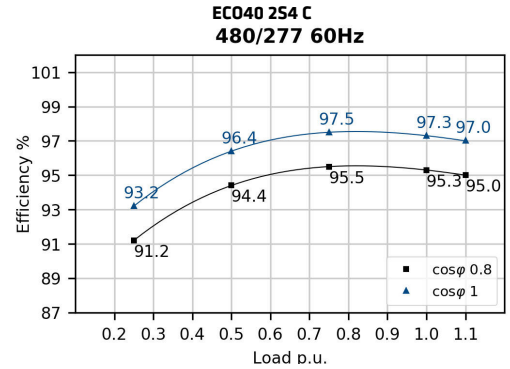
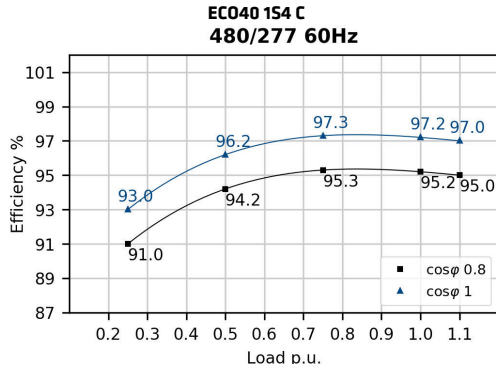

Transients voltage

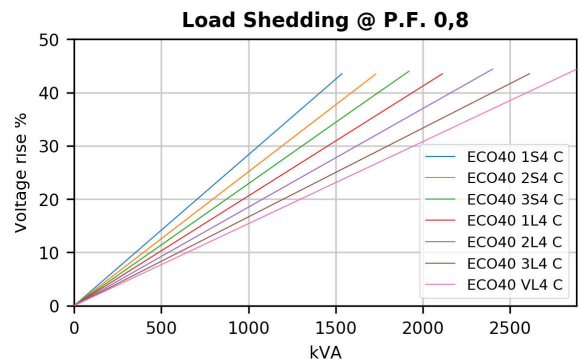
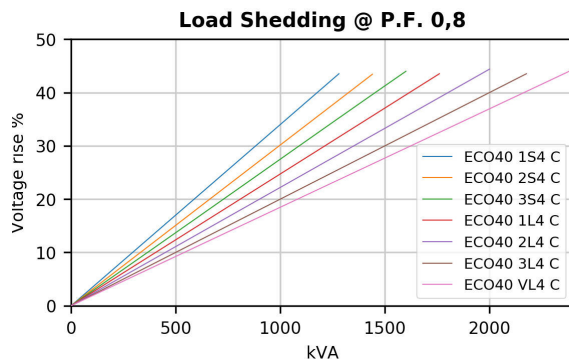
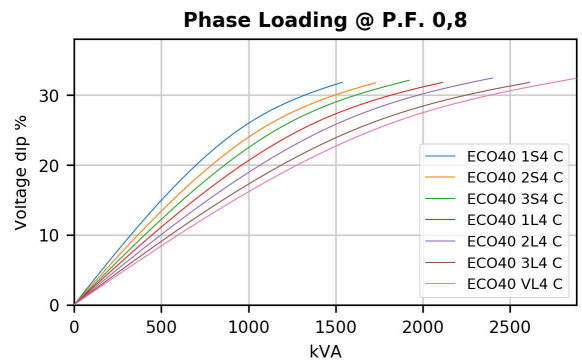
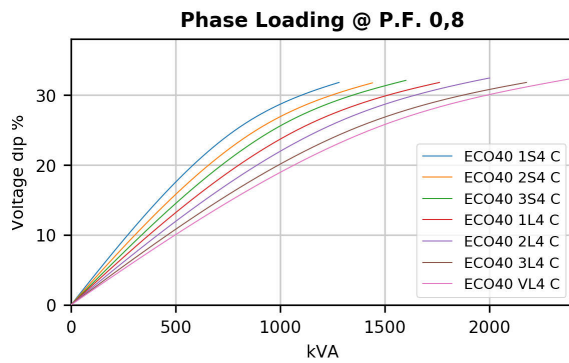
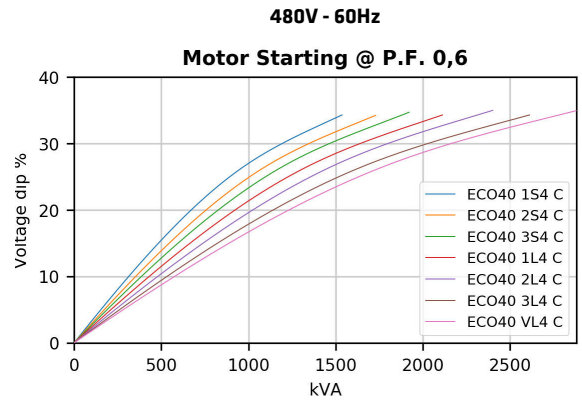
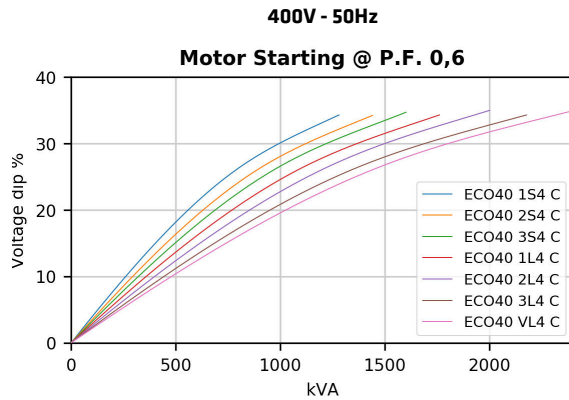

In order to scale transient curves as a function of a power factor or voltage if not indicated, please proceed as follows:

Power Factor coefficient corrector (PFCC), to be used on power factor 0.6 curves:

$$PFCC = \frac{\sin(\text{ARCCos}(PF_{\text{new}}))}{0.8}$$

Example. The PFCC at power factor 0.3 is 1.192 [$PFCC = \frac{\sin(\text{ARCCos}(0.3))}{0.8}$]. This means that the voltage fall at a given power at pf 0.3 is equivalent to the one that can be read on the pf 0.6 curve if the load is considered 1.192 times bigger (19% higher value.).

In this example, a 100 kVA load insertion at pf 0.3 is equivalent in voltage fall to a 119kVA load insertion at pf 0.6.

Voltage coefficient corrector (VCC):

$$VCC = \frac{(400/V_{\text{new}})^2}{1} \text{ if 50 Hz; } VCC = \frac{(480/V_{\text{new}})^2}{1} \text{ if 60 Hz}$$

Example. VCC at 415V 60 Hz is 1.338 [$VCC = \frac{(480/415)^2}{1}$]. This means that the voltage fall at a given power at 415V is equivalent to the one that can be read on the power factor 0.6 curve if the load is considered 1.338 times bigger (33% higher value.).

In this example, a 100 kVA load insertion at 415V is equivalent in voltage fall to a 133kVA load insertion at 480V.

50Hz Short circuit decrement curves - No load excitation at rated speed

ECO40 1S4 C

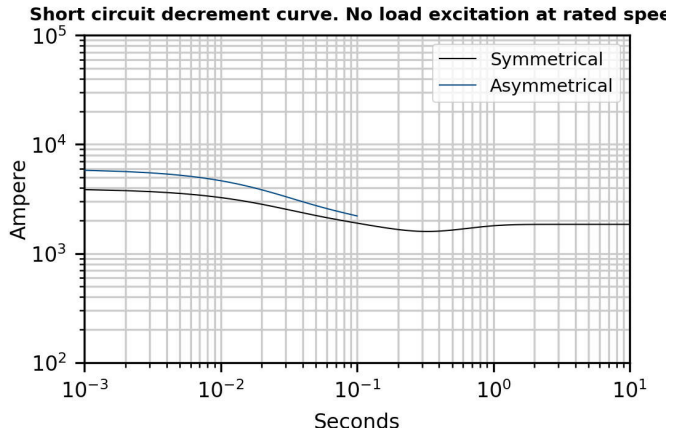

ECO40 2S4 C

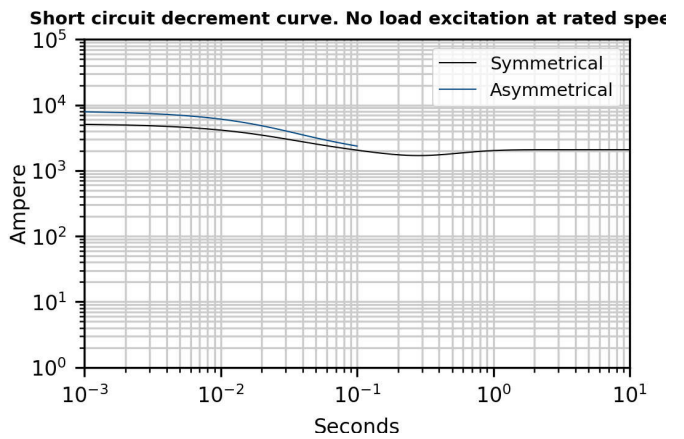

ECO40 3S4 C

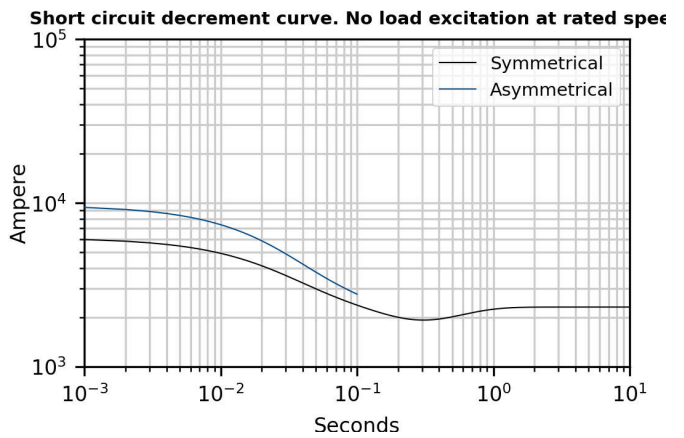

ECO40 1L4 C

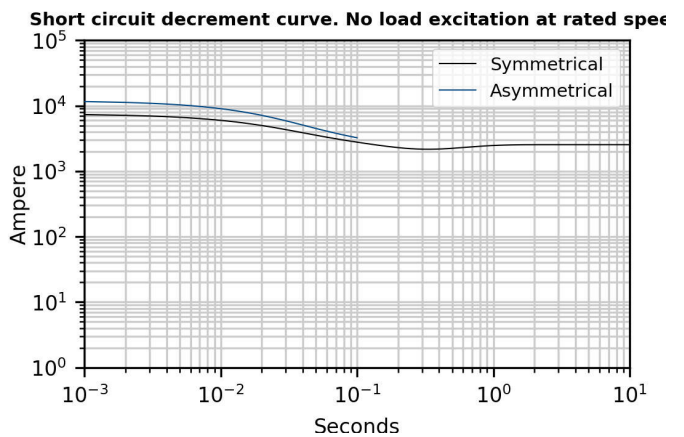

*Please refer to tables at page 6

50Hz Short circuit decrement curves - No load excitation at rated speed

ECO40 2L4 C

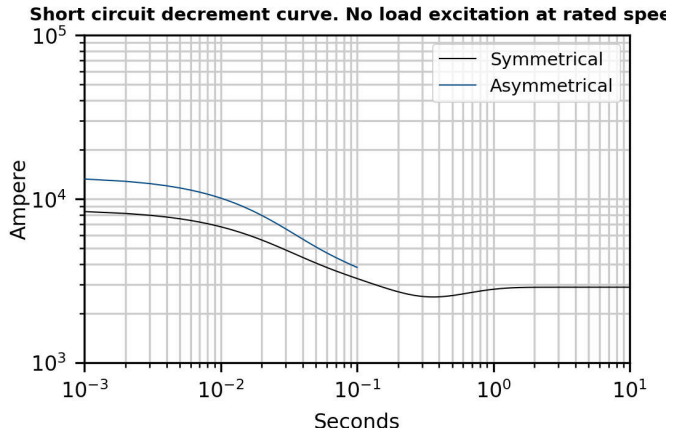

ECO40 3L4 C

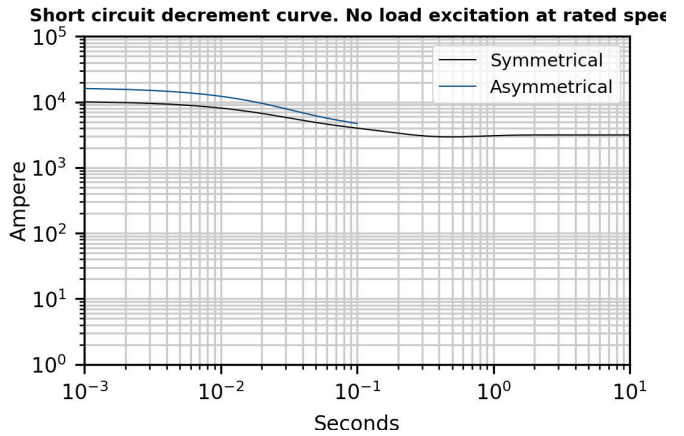

ECO40 VL4 C

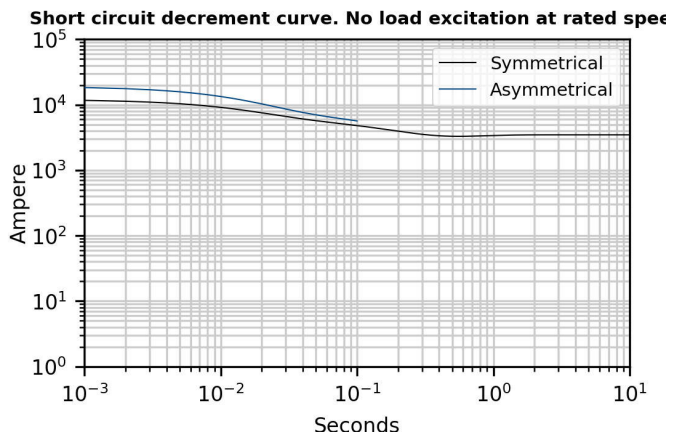

*Please refer to tables at page 6

60Hz Short circuit decrement curves - No load excitation at rated speed

ECO40 1S4 C

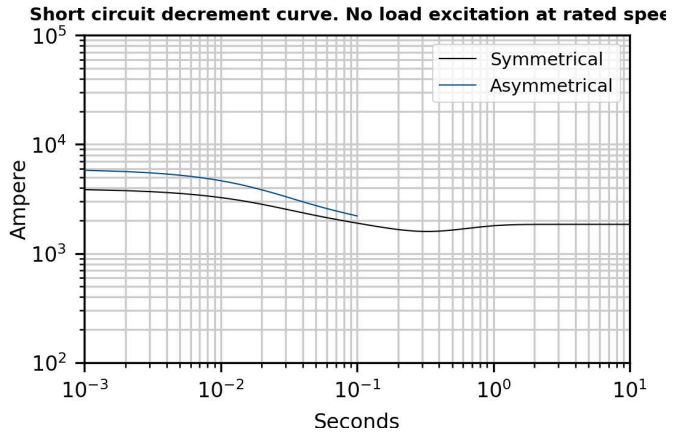

ECO40 2S4 C

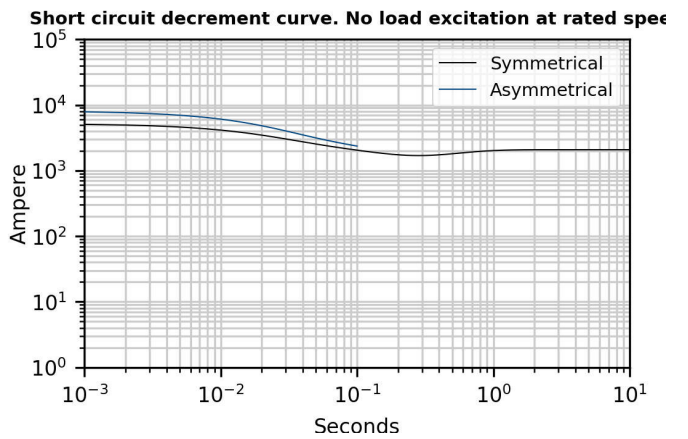

ECO40 3S4 C

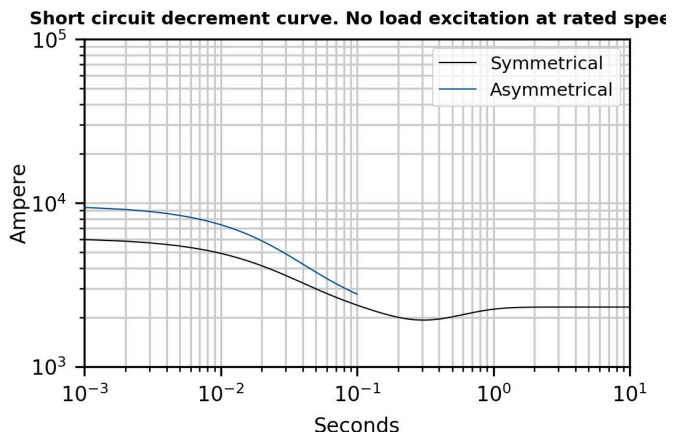

ECO40 1L4 C

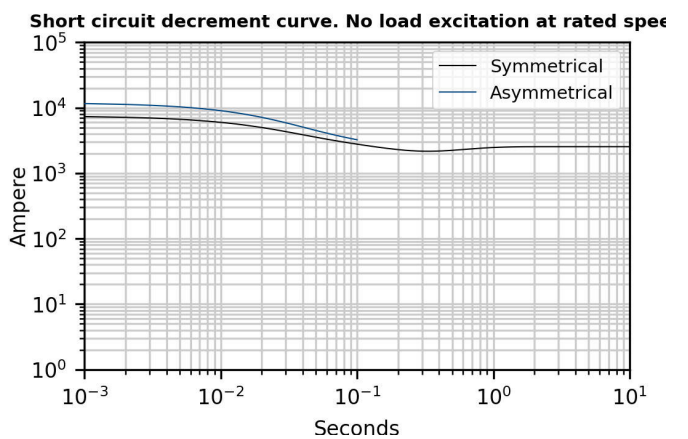

*Please refer to tables at page 6

60Hz Short circuit decrement curves - No load excitation at rated speed

ECO40 2L4 C

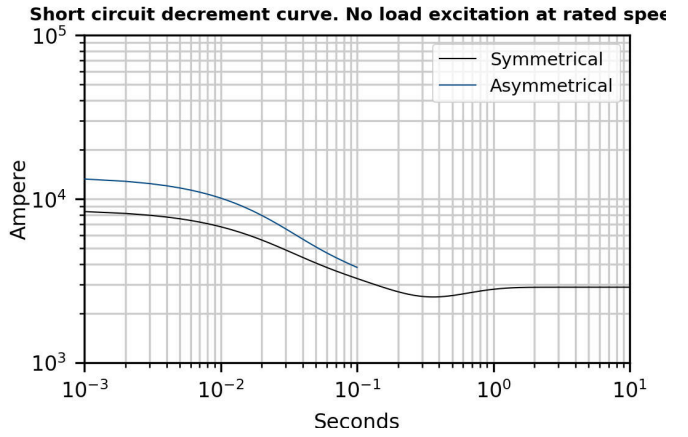

ECO40 3L4 C

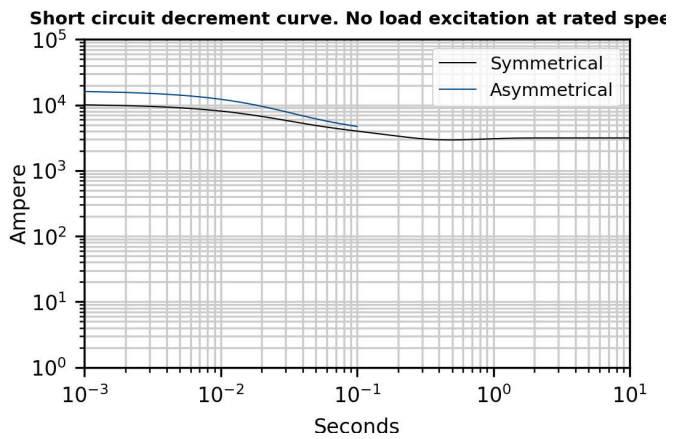

ECO40 VL4 C

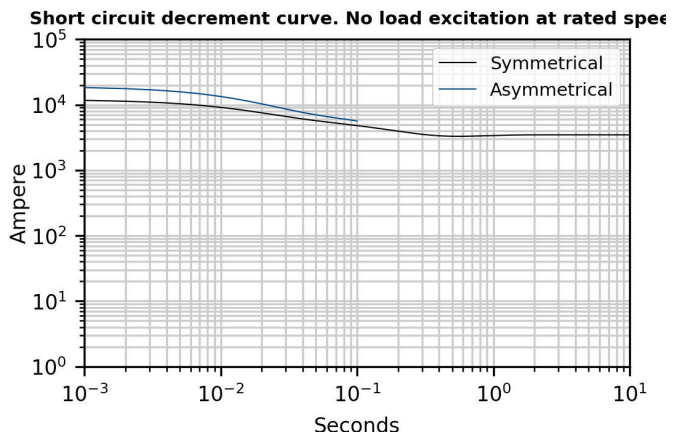

*Please refer to tables at page 6

Additional Characteristics

Data	ECO40 1S4 C		ECO40 2S4 C		ECO40 3S4 C		ECO40 1L4 C		ECO40 2L4 C		ECO40 3L4 C		ECO40 VL4 C		
	50Hz	60Hz	50Hz	60Hz	50Hz	60Hz	50Hz	60Hz	50Hz	60Hz	50Hz	60Hz	50Hz	60Hz	
Damper cage	Copper														
Stator Winding Resistance (20°C)	Ω	0,017		0,013		0,014		0,01		0,0086		0,009		0,008	
Rotor Winding Resistance (20°C)	Ω	4,488		4,881		5,176		6,025		1,376		1,5		1,592	
Stator Exciter Resistance (20°C)	Ω	8,85		8,85		8,85		8,85		8,85		8,85		8,85	
Rotor Exciter Resistance (20°C)	Ω	0,317		0,317		0,317		0,317		0,05		0,05		0,05	
Weight of complete generator	kg	1049,0		1133,0		1208,0		1323,0		1458,0		1536,0		1752,0	
Unbalanced magnetic pull	kN/mm	5,0		5,9		6,5		6,1		6,5		6,8		6,9	
Air flow	m ³ /min	54,0	64,8	54,0	64,8	54,0	64,8	54,0	64,8	54,0	64,8	54,0	64,8	54,0	64,8
Noise level at 1m/7m	dB(A)	94/82	98/88	94/82	98/88	94/82	98/88	94/82	98/88	94/82	98/88	94/82	98/88	94/82	98/88

PQ Diagram

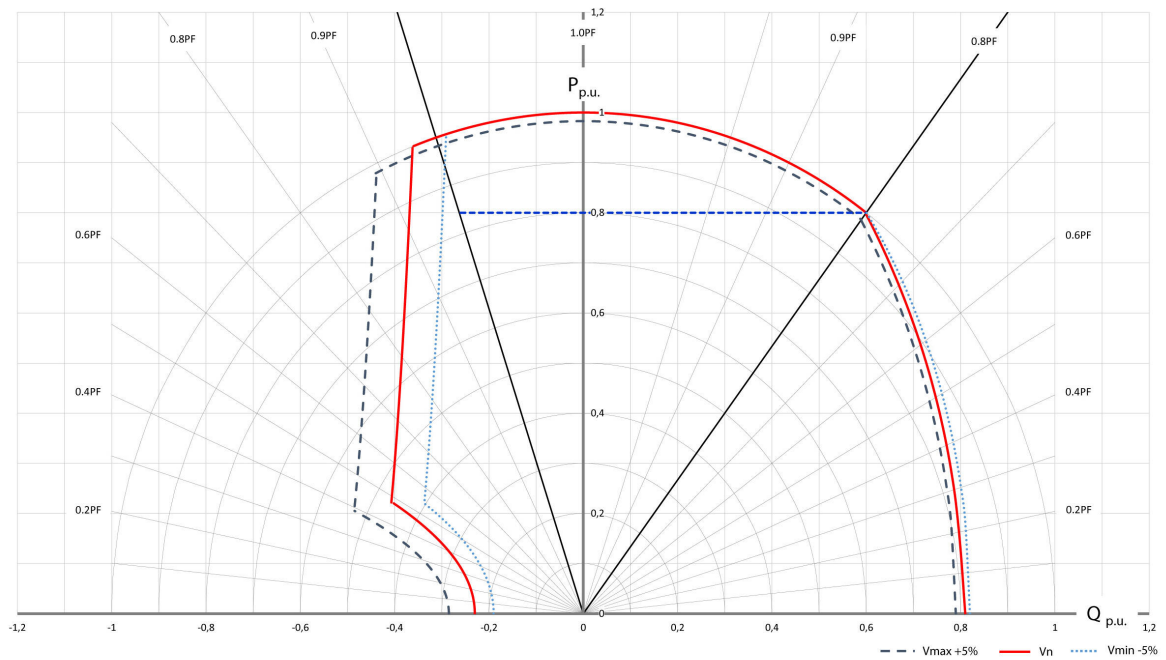

MOMENTS OF INERTIA - DOUBLE BEARING

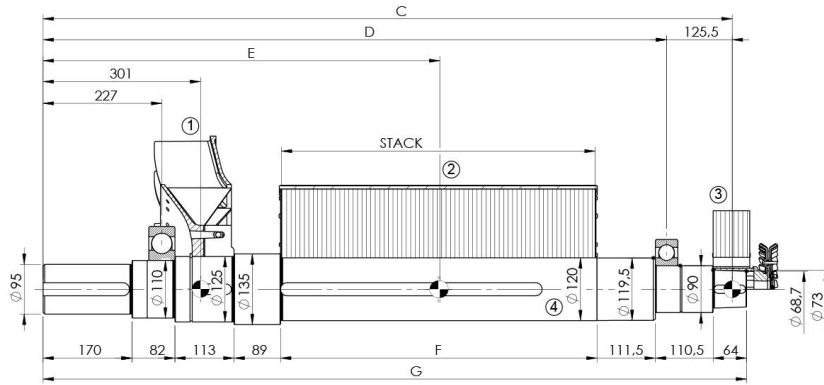

POS.	1		2		3		4		TOTAL	
	FAN		MAIN ROTOR		EXCITER ROTOR		SHAFT *			
COMPONENT	WEIGHT	J	WEIGHT	J	WEIGHT	J	WEIGHT	J	WEIGHT	J
TYPE	[kg]	[kgm ²]	[kg]	[kgm ²]	[kg]	[kgm ²]	[kg]	[kgm ²]	[kg]	[kgm ²]
ECO40 1S / 4C			215,8	4,4392					348,8	5,4629
ECO40 2S / 4C			249,1	5,1183			83,3	0,1435	382,1	6,1420
ECO40 3S / 4C			277,9	5,7070					410,9	6,7307
ECO40 1L / 4C	12,4	0,4387	306,8	6,2966	37,3	0,4415			454,5	7,3471
ECO40 2L / 4C			339,8	6,8833			98,0	0,1703	487,6	7,9338
ECO40 3L / 4C			353,3	7,1545					501,0	8,2050
ECO40 VL / 4C			435,0	8,8036			107,0	0,1866	591,7	9,8704

TYPE	DIMENSION				
	C [mm]	D [mm]	E [mm]	F [mm]	G [mm]
ECO40 1S / 4C			580,5		
ECO40 2S / 4C	1052,5	927,0	603,0	340,0	1080,0
ECO40 3S / 4C			623,0		
ECO40 1L / 4C			643,0		
ECO40 2L / 4C	1217,5	1092,0	685,5	505,0	1245,0
ECO40 3L / 4C			695,5		
ECO40 VL / 4C	1317,5	1192,0	755,5	605,0	1345,0

* Shaft mass and inertia also include rotor keys

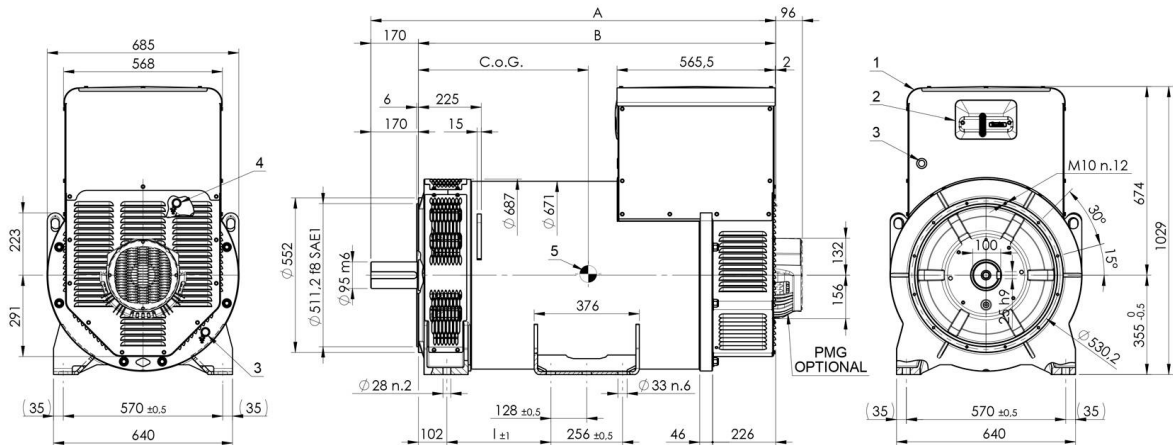

TIPO / TYPE	CoG [mm]		A [mm]	B [mm]	I [mm]
	Standard version	PMG version			
ECO40 1S / 4C	446	457			
ECO40 2S / 4C	457	467	1183	1013	207
ECO40 3S / 4C	467	477			
ECO40 1L / 4C	515	525			
ECO40 2L / 4C	539	548	1348	1178	372
ECO40 3L / 4C	545	554			
ECO40 VL / 4C	601	609	1448	1278	372

- 1) REMOVABLE COVER FOR ACCESS TO MAIN TERMINALS
- 2) REMOVABLE PANEL FOR ACCESS TO AVR
- 3) RUBBER GROMMET - DG21
- 4) SCREWS M16 FOR GROUNDING
- 5) CENTER OF GRAVITY (C.o.G.) - NO OPTIONAL MOUNTED

MOMENTS OF INERTIA - SINGLE BEARING

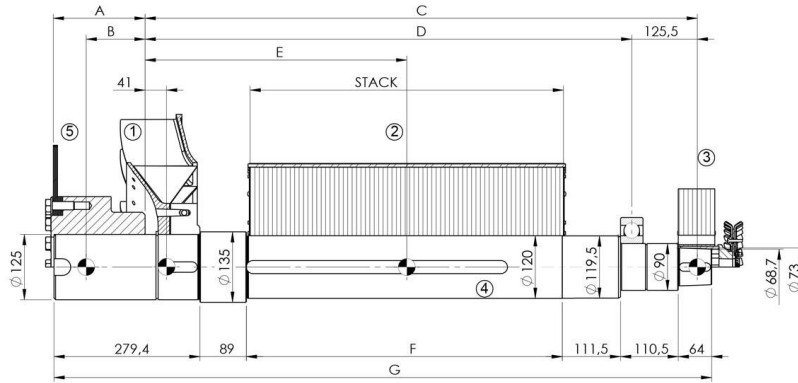

SAE N.	5 SHAFTS COUPLING FLEX PLATE			
	A	B	WEIGHT [kg]	J [kgm ²]
14	175,7	112,8	55,1	0,7503
18	165,7	113,8	58,2	1,0848

POS. COMPONENT	1 FAN		2 MAIN ROTOR		3 EXCITER ROTOR		4 SHAFT *		TOTAL	
	WEIGHT [kg]	J [kgm ²]	WEIGHT [kg]	J [kgm ²]	WEIGHT [kg]	J [kgm ²]	WEIGHT [kg]	J [kgm ²]	WEIGHT [kg]	J [kgm ²]
ECO40 1S / 4C			215,8	4,4392			83,5	0,1541	349,0	5,4735
ECO40 2S / 4C			249,1	5,1183					382,3	6,1526
ECO40 3S / 4C			277,9	5,7070					411,1	6,7413
ECO40 1L / 4C	12,4	0,4387	306,8	6,2966	37,3	0,4415			454,7	7,3577
ECO40 2L / 4C			338,5	6,8582			98,2	0,1809	486,4	7,9193
ECO40 3L / 4C			353,3	7,1545					501,2	8,2156
ECO40 VL / 4C			435,0	8,8036			107,2	0,1972	591,9	9,8810

DIMENSION TYPE	C	D	E	F	G
	[mm]	[mm]	[mm]	[mm]	[mm]
ECO40 1S / 4C			326,1		
ECO40 2S / 4C	792,5	667,0	348,6	340,0	994,4
ECO40 3S / 4C			368,6		
ECO40 1L / 4C			388,6		
ECO40 2L / 4C	957,5	832,0	431,1	505,0	1159,4
ECO40 3L / 4C			441,1		
ECO40 VL / 4C	1057,5	932,0	501,1	605,0	1259,4

* Shaft mass and inertia also include rotor keys

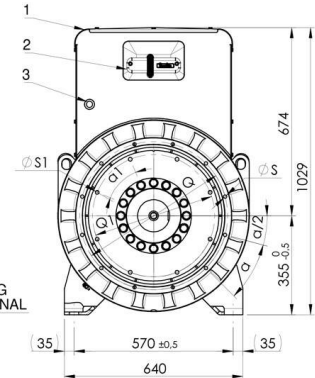
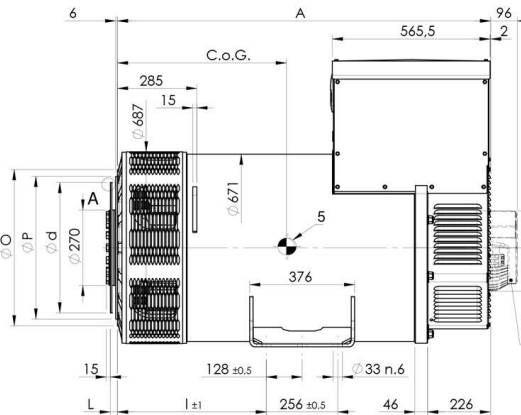
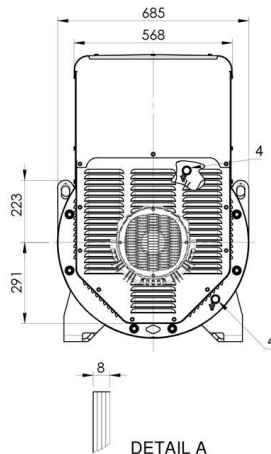

TIPO / TYPE	CoG [mm]		A [mm]	I [mm]
	Standard version	PMG version		
ECO40 1S / 4C	482	493	1073	369
ECO40 2S / 4C	494	504		
ECO40 3S / 4C	505	515		
ECO40 1L / 4C	553	563	1238	534
ECO40 2L / 4C	578	587		
ECO40 3L / 4C	585	593		
ECO40 VL / 4C	642	650	1338	534

SAE N.	FLANGIA / FLANGE BRIDE / FLANSCH					
	O	P	Q	S	N	α
1	560	511,2	530,2	12	12	30°
1/2	654	584,2	619,1	14	12	30°
0	711	647,7	679,5	14	16	22,5°

SAE N.	GIUNTI A DISCHI / DISC COUPLING DISQUE DE MONOPALIER / SCHEIBENKUPPLUNG				
	d	L	Q1	S1	N1 α1
14	466,72	25,4	438,15	13,5	8 45
18	571,50	15,7	542,92	16,7	6 60

- 1) REMOVABLE COVER FOR ACCESS TO MAIN TERMINALS
- 2) REMOVABLE PANEL FOR ACCESS TO AVR
- 3) RUBBER GROMMET DG-21
- 4) SCREWS M16 FOR GROUNDING
- 5) CENTER OF GRAVITY (C.o.G.) IN CONFIGURATION SAE 1 FLYWHEEL 14 -NO OPTIONAL MOUNTED

Notes

Mecc Alte SpA (HQ)

Via Roma
20 - 36051 Creazzo
Vicenza - ITALY
T: +39 0444 396111
E: info@meccalte.it
aftersales@meccalte.it

Mecc Alte Portable

Via Roma
20 - 36051 Creazzo
Vicenza - ITALY
T: +39 0444 396111
E: info@meccalte.it

Mecc Alte Power Products srl

Via Melaro
2 - 36075 Montecchio
Maggiore (VI) - ITALY
T: +39 0444 1831295
E: info@meccalte.it

Zanardi Alternatori srl

Via Dei Laghi
48/B - 36077 Altavilla
Vicenza - ITALY
T: +39 0444 370799
E: info@zanardialternatori.it

United Kingdom

Mecc Alte U.K. LTD
6 Lands' End Way
Oakham
Rutland LE15 6RF
T: +44 (0) 1572 771160
E: info@meccalte.co.uk

Spain

Mecc Alte España S.A.
C/ Rio Taibilla, 2
Polig. Ind. Los Valeros
03178 Benijofar (Alicante)
T: +34 (0) 96 6702152
E: info@meccalte.es

China

Mecc Alte Alternator Haimen LTD
755 Nanghai East Rd
Jiangsu HEDZ 226100 PRC
T: +86 (0) 513 82325758
E: info@meccalte.cn

India

Mecc Alte India PVT LTD
Plot NO: 1, Sanaswadi
Talegaon
Dhamdhare Road Taluka:
Shirur, District:
Pune - 412208
Maharashtra, India
T: +91 2137 619600
E: info@meccalte.in

U.S.A. and Canada

Mecc Alte Inc.
1229 Adams Drive
McHenry, IL, 60051
T: +1 815 344 0530
E: info@meccalte.us

Germany

Mecc Alte Generatoren GmbH
Bucher Hang 2
D-87448 Waltenhofen
T: +49 (0)831 540755 0
E: info@meccalte.de

Australia

Mecc Alte Alternators PTY LTD
10 Duncan Road, PO Box 1046
Dry Creek, 5094, South
Australia
T: +61 (0) 8 8349 8422
E: info@meccalte.com.au

France

Mecc Alte International S.A.
Z.E.La Gagnerie
16330 ST.Amant de Boixe
T: +33 (0) 545 397562
E: info@meccalte.fr

Far East

Mecc Alte (F.E.) PTE LTD
19 Kian Teck Drive
Singapore 628836
T: +65 62 657122
E: info@meccalte.com.sg



www.meccalte.com